

**CALENDAR ITEM
C24**

A 10
S 3

04/23/14
PRC 8452.1
J. Sampson

GENERAL LEASE – RECREATIONAL USE

APPLICANTS:

Frank Chiu-Ng Tsang and Judy Ming-Ming Sze Tsang as Co-Trustees of The Frank Chiu-Ng Tsang and Judy Ming-Ming Sze Tsang 2003 Trust established May 5, 2003

AREA, LAND TYPE, AND LOCATION:

Sovereign submerged land located in the Petaluma River, adjacent to 6300 Lakeville Highway, city of Petaluma, Sonoma County.

AUTHORIZED USE:

Continued use and maintenance of an existing pier, gangway, floating boat dock, and two pilings.

LEASE TERM:

10 years, beginning April 30, 2013.

CONSIDERATION:

\$373 per year, with the State reserving the right to set a different rent periodically during the lease term.

SPECIFIC LEASE PROVISIONS:

Liability insurance in an amount no less than \$1,000,000 per occurrence.

OTHER PERTINENT INFORMATION:

1. Applicants own the upland adjoining the lease premises.
2. On April 7, 2003, the Commission authorized issuance of a Recreational Pier Lease to Frank Tsang and Judy Ming-Ming-Sze Tsang. The lease expired on April 29, 2013. The upland property has since been deeded to the Applicants who are now applying for a General Lease – Recreational Use.

CALENDAR ITEM NO. **C24** (CONT'D)

3. The staff recommends that the Commission find that this activity is exempt from the requirements of the California Environmental Quality Act (CEQA) as a categorically exempt project. The project is exempt under Class 1, Existing Facilities; California Code of Regulations, Title 2, section 2905, subdivision (a)(2).

Authority: Public Resources Code section 21084 and California Code of Regulations, Title 14, section 15300 and California Code of Regulations, Title 2, section 2905.

4. This activity involves lands identified as possessing significant environmental values pursuant to Public Resources Code section 6370 et seq., but such activity will not affect those significant lands. Based upon the staff's consultation with the persons nominating such lands and through the CEQA review process, it is the staff's opinion that the project, as proposed, is consistent with its use classification.

EXHIBITS:

- A. Land Description
- B. Site and Location Map

RECOMMENDED ACTION:

It is recommended that the Commission:

CEQA FINDING:

Find that the activity is exempt from the requirements of CEQA pursuant to California Code of Regulations, Title 14, section 15061 as a categorically exempt project, Class 1, Existing Facilities; California Code of Regulations, Title 2, section 2905, subdivision (a)(2).

SIGNIFICANT LANDS INVENTORY FINDING:

Find that this activity is consistent with the use classification designated by the Commission for the land pursuant to Public Resources Code section 6370 et seq.

AUTHORIZATION:

Authorize issuance of a General Lease – Recreational Use to Frank Chiu- Ng Tsang and Judy Ming-Ming Sze Tsang as Co-Trustees of The Frank Chiu- Ng Tsang and Judy Ming-Ming Sze Tsang 2003 Trust established May 5, 2003, beginning April 30, 2013, for a term of 10 years, for the continued use and maintenance of an existing pier, gangway, floating boat

CALENDAR ITEM NO. **C24** (CONT'D)

dock, and two pilings as described on Exhibit A and shown on Exhibit B for reference purposes only, attached and by this reference made a part hereof; annual rent in the amount of \$373 per year, with the State reserving the right to set a different rent periodically during the lease term; liability insurance in an amount no less than \$1,000,000 per occurrence.

EXHIBIT A

PRC 8452.1

LAND DESCRIPTION

A parcel of submerged land lying in the bed of the Petaluma River, adjacent to Tideland Survey 22, patented on 10/27/1874, County of Sonoma, State of California, described as follows:

BEGINNING at a point on Boundary Line Agreement 59, as shown on that Record of Survey filed in Book 100 of Maps, Page 55, Sonoma County Records, said point lying distant N 50°26'00" W 64.34 feet from the northerly terminus of that course shown as N 3°10'00" E 18.00 feet as shown on said Record of Survey; thence leaving said Boundary Line the following seven (7) courses:

- 1) S 53°55'05" W 237.20 feet;
- 2) S 36°04'55" E 12.84 feet;
- 3) S 53°55'05" W 21.00 feet;
- 4) N 36°04'55" W 37.64 feet;
- 5) N 53°55'05" E 67.19 feet;
- 6) S 36°04'55" E 14.20 feet;
- 7) N 53°55'05" E 188.30 feet to a point on said Boundary Line Agreement 59; thence along said Boundary Line S 50°26'00" E 10.94 feet to the POINT OF BEGINNING.

END OF DESCRIPTION

Prepared 03/11/2014 by the California State Lands Commission Boundary Unit.



NO SCALE

SITE

APN 068-060-039

PETALUMA RIVER

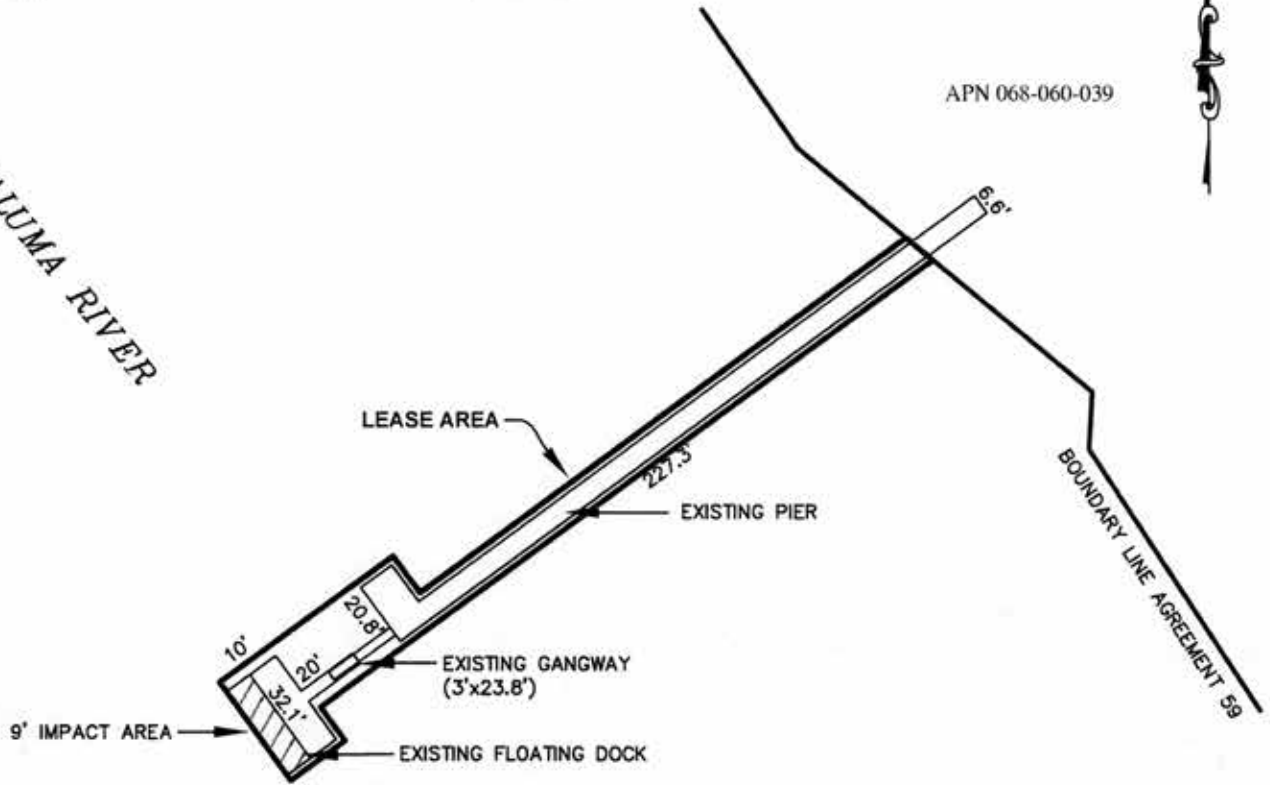

6300 LAKEVILLE HWY, PETALUMA

NO SCALE

LOCATION



MAP SOURCE: USGS QUAD

Exhibit B

PRC 8452.1
 TSANG TRUST
 APN 068-060-038 & 039
 GENERAL LEASE -
 RECREATIONAL USE
 SONOMA COUNTY



DJF 03/12/14

This Exhibit is solely for purposes of generally defining the lease premises, is based on unverified information provided by the Lessee or other parties and is not intended to be, nor shall it be construed as, a waiver or limitation of any State interest in the subject or any other property.