

**CALENDAR ITEM  
C04**

A 11

12/02/13

S 3

PRC 7737.1  
G. Asimakopoulos

**AUTHORIZE ACCEPTANCE OF A LEASE QUITCLAIM DEED AND ISSUANCE OF A  
GENERAL LEASE – RECREATIONAL AND PROTECTIVE STRUCTURE USE**

**LESSEE:**

Terrence L. Cashen

**APPLICANT:**

Peter Vincent McNally

**AREA, LAND TYPE, AND LOCATION:**

Sovereign land in Georgiana Slough, adjacent to 421 West Willow Tree Lane, near the city of Isleton, Sacramento County.

**AUTHORIZED USE:**

Continued use and maintenance of an existing single-berth uncovered floating boat dock with boat lift, gangway, walkway, four pilings, and bank protection.

**LEASE TERM:**

10 years, beginning May 3, 2013.

**CONSIDERATION:**

**Single-Berth Uncovered Floating Boat Dock with Boat Lift, Gangway, Walkway, and Four Pilings:** \$160 per year, with the State reserving the right to fix a different rent periodically during the lease term, as provided in the lease.

**Bank Protection:** The public use and benefit, with the State reserving the right at any time to set a monetary rent if the Commission finds such action to be in the State's best interest.

**SPECIFIC LEASE PROVISIONS:**

Liability insurance in an amount no less than \$1,000,000 per occurrence.

CALENDAR ITEM NO. **C04** (CONT'D)

**OTHER PERTINENT INFORMATION:**

1. Applicant owns the upland adjoining the lease premises.
2. On August 17, 2004, the Commission authorized a 10-year General Lease – Protective Structure and Recreational Use to Terrence L. Cashen. That lease will expire on December 31, 2013. On May 3, 2013, the upland was deeded to Peter Vincent McNally. The Applicant is now applying for a new General Lease – Recreational and Protective Structure Use. The lessee has executed a lease quitclaim deed releasing his interest in the existing lease to the State.
3. The bank protection will mutually benefit both the public and the Applicant. The bank of Georgiana Slough will have additional protection from wave action provided at no cost to the public.
4. **Lease Quitclaim Deed:** The staff recommends that the Commission find that the subject lease quitclaim deed does not have a potential for resulting in either a direct or a reasonably foreseeable indirect physical change in the environment, and is, therefore, not a project in accordance with the California Environmental Quality Act (CEQA).

Authority: Public Resources Code section 21065 and California Code of Regulations, Title 14, sections 15060, subdivision (c)(3), and 15378.

5. **Issuance of Lease:** The staff recommends that the Commission find that this activity is exempt from the requirements of CEQA as a categorically exempt project. The project is exempt under Class 1, Existing Facilities; California Code of Regulations, Title 2, section 2905, subdivision (a)(2).

Authority: Public Resources Code section 21084 and California Code of Regulations, Title 14, section 15300 and California Code of Regulations, Title 2, section 2905.

6. This activity involves lands which have NOT been identified as possessing significant environmental values pursuant to Public Resources Code section 6370 et seq.; however, the Commission has declared that all lands are “significant” by nature of their public ownership (as opposed to “environmentally significant”). Since such declaration of significance is not based upon the requirements and criteria of Public Resources Code section 6370 et seq., use classifications for such lands have not been designated. Therefore, the finding of the project’s consistency with the use classification as required by California Code of Regulations, Title 2, section 2954 is not applicable.

CALENDAR ITEM NO. **C04** (CONT'D)

**EXHIBITS:**

- A. Land Description
- B. Site and Location Map

**RECOMMENDED ACTION:**

It is recommended that the Commission:

**CEQA FINDING:**

**Lease Quitclaim Deed:** Find that the subject lease quitclaim deed is not subject to the requirements of CEQA pursuant to California Code of Regulations, Title 14, section 15060, subdivision (c) (3), because the subject activity is not a project as defined by Public Resources Code section 21065 and California Code of Regulations, Title 14, section 15378.

**Issuance of Lease:** Find that the activity is exempt from the requirements of CEQA pursuant to California Code of Regulations, Title 14, section 15061 as a categorically exempt project, Class 1, Existing Facilities; California Code of Regulations, Title 2, section 2905, subdivision (a)(2).

**AUTHORIZATION:**

1. Authorize acceptance of a lease quitclaim deed for, Lease No. PRC 7737.9, a General Lease – Protective Structure and Recreational Use, issued to Terrence L. Cashen.
2. Authorize issuance of a General Lease – Recreational and Protective Structure Use to Peter Vincent McNally beginning May 3, 2013, for a term of 10 years, for the continued use and maintenance of a single-berth uncovered floating boat dock with boat lift, gangway, walkway, four pilings, and bank protection, as described in Exhibit A and shown on Exhibit B (for reference purposes only) attached and by this reference made a part hereof; consideration for the single-berth uncovered floating boat dock with boat lift, gangway, walkway and four pilings: annual rent in the amount of \$160, with the State reserving the right to fix a different rent periodically during the lease term, as provided in the lease; consideration for the bank protection: the public use and benefit with the State reserving the right at any time to set a monetary rent if the Commission finds such action to be in the State's best interest; and liability insurance in an amount no less than \$1,000,000 per occurrence.

**EXHIBIT A**

**PRC 7737.1**

**LAND DESCRIPTION**

A parcel of tide and submerged land situate in the bed of the Georgiana Slough, lying adjacent to Swamp and Overflowed Land Survey 943 patented April 14, 1873, County of Sacramento, State of California and more particularly described as follows:

All those lands underlying an existing single berth uncovered floating boat dock, boat lift, gangway and walkway lying adjacent to that parcel described in Grant Deed, recorded May 3, 2013 in Book 20130503 at Page 0058 in Official Records of said County.

TOGETHER WITH a ten foot impact area.

ALSO TOGETHER WITH that land lying immediately beneath any bank protection structure adjacent to said parcel.

EXCEPTING THEREFROM any portion lying landward of the ordinary high water mark of the right bank of said slough.

Accompanying plat is hereby made part of this description.

**END OF DESCRIPTION**

Prepared 09/17/13 by the California State Lands Commission Boundary Unit





GEORGIANA SLOUGH

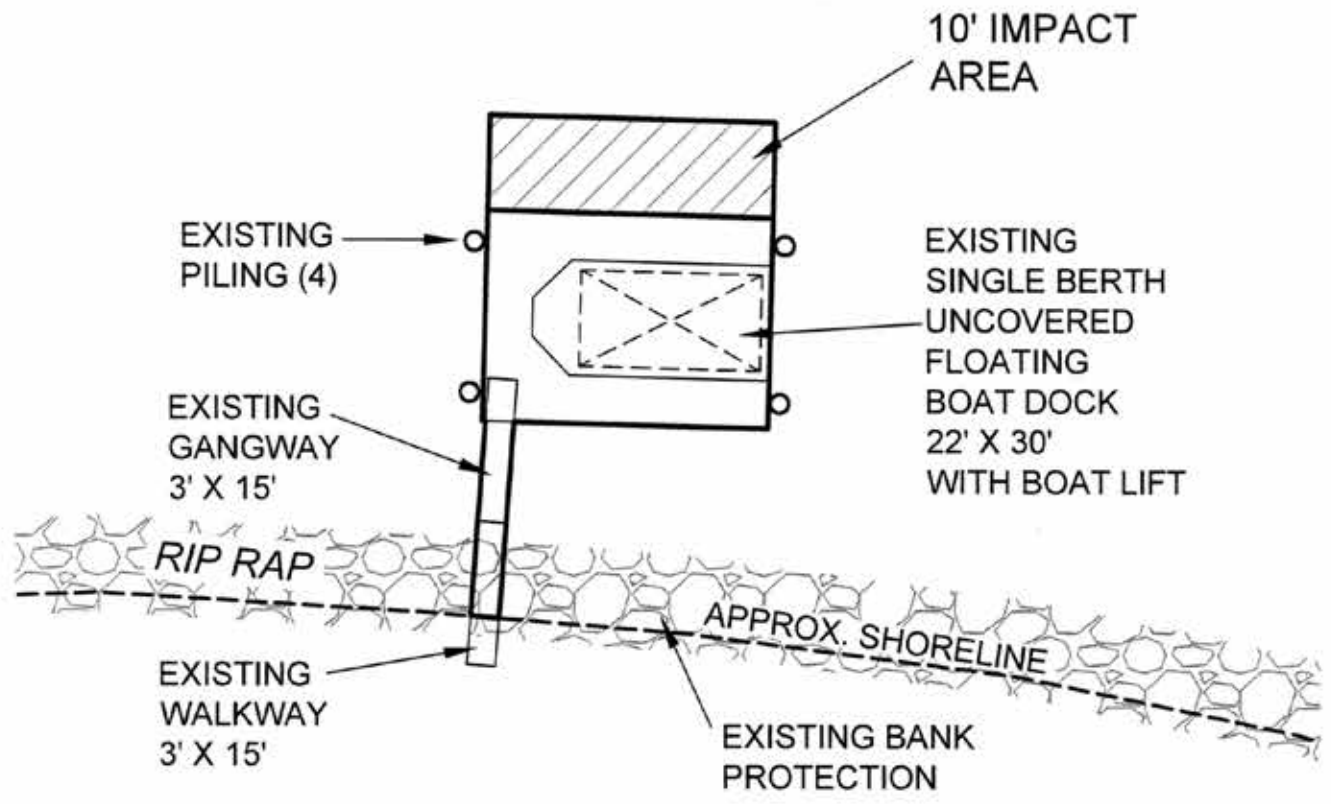

APN 156-0100-008

EXHIBIT A

Page 2 of 2

TS 09/17/13

LAND DESCRIPTION PLAT  
PRC 7737.1 MCNALLY  
SACRAMENTO COUNTY

CALIFORNIA STATE  
LANDS COMMISSION



NO SCALE

# SITE

## GEORGIANA SLOUGH



10' IMPACT AREA

EXISTING PILING (4)

EXISTING SINGLE BERTH UNCOVERED FLOATING BOAT DOCK 22' X 30' WITH BOAT LIFT

EXISTING GANGWAY 3' X 15'

RIP RAP

APPROX. SHORELINE

EXISTING WALKWAY 3' X 15'

EXISTING BANK PROTECTION

APN 156-0100-008

421 WEST WILLOW TREE LANE, NEAR ISLETON

NO SCALE

# LOCATION



MAP SOURCE: USGS QUAD

# Exhibit B

PRC 7737.1  
MCNALLY  
APN 156-0100-008  
GENERAL LEASE -  
RECREATIONAL &  
PROTECTIVE STRUCTURE USE  
SACRAMENTO COUNTY



This Exhibit is solely for purposes of generally defining the lease premises, is based on unverified information provided by the Lessee or other parties and is not intended to be, nor shall it be construed as, a waiver or limitation of any State interest in the subject or any other property.

TS 09/17/13