

PULLED

**Minute Item
C11**

**09/13/07
WP 5322
N. Lee**

**KENDRICK ELTON HOPPER
(APPLICANT)**

**Item C11 was removed from the agenda to be
heard at a subsequent meeting.**

002105

MINUTE PAGE

CALENDAR ITEM

C11

A 4

09/13/07

S 1

WP 5322.9

N. Lee

RECREATIONAL PIER LEASE

APPLICANT:

Kendrick Elton Hooper

AREA, LAND TYPE, AND LOCATION:

Sovereign lands in Lake Tahoe, near Rubicon Bay, El Dorado County.

AUTHORIZED USE:

Continued use and maintenance of two existing mooring buoys as shown on the attached Exhibit A.

LEASE TERM:

Ten years, beginning July 1, 2007.

CONSIDERATION:

No monetary consideration pursuant to Public Resources Code section 6503.5.

SPECIFIC LEASE PROVISIONS:

Insurance:

Liability insurance in the amount of no less than \$300,000.

Other:

The lease contains a provision which requires the Applicant to obtain authorization from the Tahoe Regional Planning Agency (TRPA) for the mooring buoys within two years after the adoption of the Lake Tahoe Shorezone Amendments-Final Environmental Impact Statement (FEIS) and approval of the ordinances based on the FEIS.

OTHER PERTINENT INFORMATION:

1. Applicant owns the upland property adjoining the lease premises.
2. On June 19, 1998, the Commission authorized a Recreational Pier Lease with Louis G. Hooper and Rita T. Hooper. That lease expired on

CALENDAR ITEM NO. C11 (CONT'D)

June 30, 2007 and the upland property has since been deeded to Kendrick Elton Hooper. Applicant is now applying for a new Recreational Pier Lease.

3. Applicant qualifies for a Recreational Pier Lease because he is a natural person who owns the littoral land that is improved with a single-family dwelling.
4. Pursuant to the Commission's delegation of authority and the State CEQA Guidelines (Title 14, California Code of Regulations, section 15061), the staff has determined that this activity is exempt from the requirements of the CEQA as a categorically exempt project. The project is exempt under Class 1, Existing Facilities; Title 2, California Code of Regulations, section 2905 (a)(2).

Authority: Public Resources Code section 21084 and Title 14, California Code of Regulations, section 15300 and Title 2, California Code of Regulations, section 2905.

5. This activity involves lands identified as possessing significant environmental values pursuant to Public Resources Code sections 6370, et seq. Based upon the staff's consultation with the persons nominating such lands and through the CEQA review process, it is the staff's opinion that the project, as proposed, is consistent with its use classification.

APPROVALS REQUIRED:

Buoys: Tahoe Regional Planning Agency

EXHIBIT:

- A. Site and Location Map

RECOMMENDED ACTION:

IT IS RECOMMENDED THAT THE COMMISSION:

CEQA FINDING:

FIND THAT THE ACTIVITY IS EXEMPT FROM THE REQUIREMENTS OF THE CEQA PURSUANT TO TITLE 14, CALIFORNIA CODE OF REGULATIONS, SECTION 15061 AS A CATEGORICALLY EXEMPT PROJECT, CLASS 1, EXISTING FACILITIES; TITLE 2, CALIFORNIA CODE OF REGULATIONS, SECTION 2905 (a)(2).

CALENDAR ITEM NO. C11 (CONT'D)

SIGNIFICANT LANDS INVENTORY FINDING:

FIND THAT THIS ACTIVITY IS CONSISTENT WITH THE USE CLASSIFICATION DESIGNATED BY THE COMMISSION FOR THE LAND PURSUANT TO PUBLIC RESOURCES CODE SECTIONS 6370, ET SEQ.

AUTHORIZATION:

AUTHORIZE ISSUANCE TO KENDRICK ELTON HOOPER, OF A TEN-YEAR RECREATIONAL PIER LEASE, BEGINNING JULY 1, 2007, FOR CONTINUED USE AND MAINTENANCE OF TWO EXISTING MOORING BUOYS AS SHOWN ON EXHIBIT A ATTACHED AND BY THIS REFERENCE MADE A PART HEREOF; NO MONETARY CONSIDERATION PURSUANT TO PUBLIC RESOURCES CODE SECTION 6503.5; LIABILITY INSURANCE IN THE AMOUNT OF NO LESS THAN \$300,000.

NO SCALE

SITE MAP

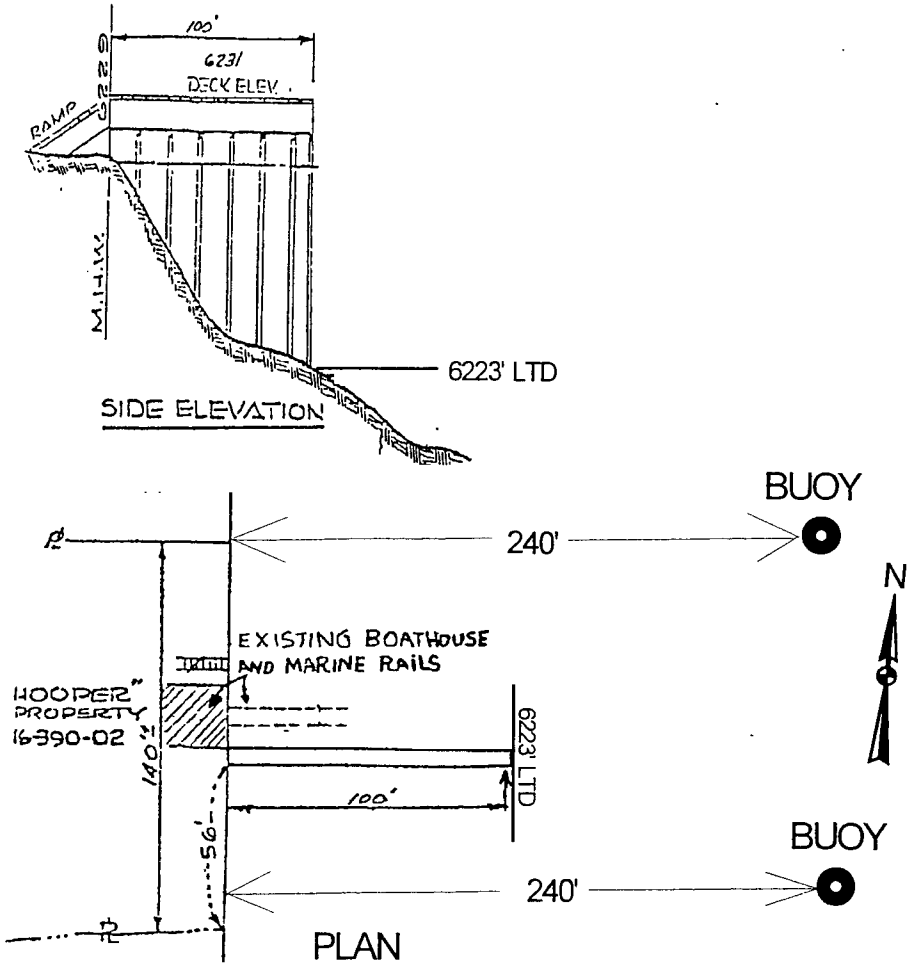

Rubicon Bay

NO SCALE

LOCATION MAP

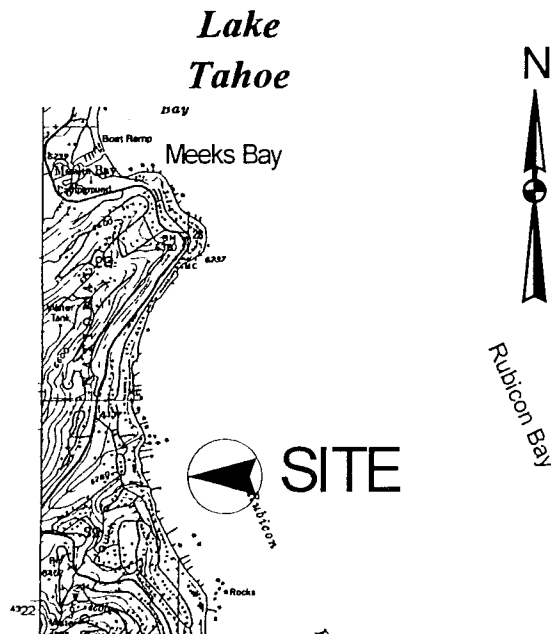
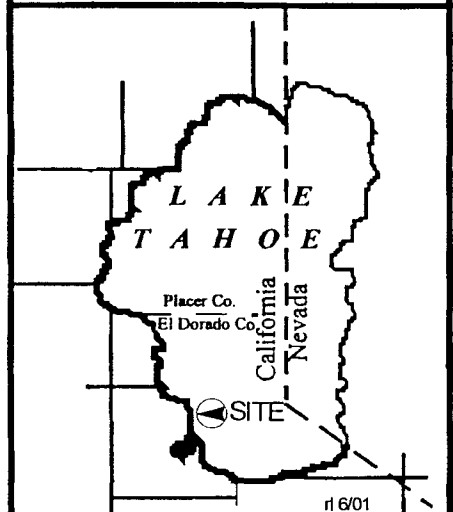

Exhibit A
 PRC 5322
 APN 016-390-02
 Lake Tahoe
 EL DORADO COUNTY



This Exhibit is solely for purposes of generally defining the lease premises, and is not intended to be, nor shall it be construed as, a waiver or limitation of any State interest in the subject or any other property.