

MINUTE ITEM
This Calendar Item No. C54
was approved as Minute Item
No. 54 by the State Lands
Commission by a vote of 3
to 6 at its 02-05-01
meeting

CALENDAR ITEM
C54

A 6
S 3

02/05/01
W 25676
F. Singer

GENERAL LEASE - PUBLIC AGENCY USE

LESSEE:

San Francisco State University
Romberg Tiburon Center for Environmental Studies
3150 Paradise Drive
Tiburon, California 94920

AREA, LAND TYPE, AND LOCATION:

Sovereign lands in the San Francisco Bay, near the city of Tiburon, Marin County.

AUTHORIZED USE:

Construction, use, and maintenance of a 300 foot long, 8-inch diameter salt-water intake pipeline, and drainage rock and rip-rap appurtenant thereto.

LEASE TERM:

Fifteen years, beginning January 1, 2001.

CONSIDERATION:

The public use and benefit; with the State reserving the right at any time to set a monetary rent if the Commission finds such action to be in the State's best interest.

OTHER PERTINENT INFORMATION:

1. Applicant owns the uplands adjoining the lease premises. The main purpose of this pipeline is to provide bay water for biological and oceanographic research at the Romberg Tiburon Center. In addition, the Tiburon Fire Department will tap into the pipeline on the upland and divert water for fire fighting purposes.
2. Pursuant to the Commission's delegation of authority and the State CEQA Guidelines (Title 14, California Code of Regulations, section 15061), the

CALENDAR ITEM NO. C54 (CONT'D)

staff has determined that this activity is exempt from the requirements of the CEQA under the general rule that the CEQA applies only to projects which have the potential for causing a significant effect on the environment. The staff believes, based on the information available to it, that there is no possibility that this project may have a significant effect on the environment.

Authority: Title 14, California Code of Regulations, section 15061 (b)(3).

3. This activity involves lands identified as possessing significant environmental values pursuant to Public Resources Code sections 6370, et seq. Based upon the staff's consultation with the persons nominating such lands and through the CEQA review process, it is the staff's opinion that the project, as proposed, is consistent with its use classification.

FURTHER APPROVALS REQUIRED:

San Francisco Bay Conservation and Development Commission, United States Army Corps of Engineers.

EXHIBIT:

- A. Site Map and Location Map

PERMIT STREAMLINING ACT DEADLINE:

January 21, 2001

RECOMMENDED ACTION:

IT IS RECOMMENDED THAT THE COMMISSION:

CEQA FINDING:

FIND THAT THE ACTIVITY IS EXEMPT FROM THE REQUIREMENTS OF THE CEQA PURSUANT TO TITLE 14, CALIFORNIA CODE OF REGULATIONS, SECTION 15061 BECAUSE THERE IS NO POSSIBILITY THAT THE ACTIVITY MAY HAVE A SIGNIFICANT EFFECT ON THE ENVIRONMENT; TITLE 14, CALIFORNIA CODE OF REGULATIONS, SECTION 15061 (b)(3).

SIGNIFICANT LANDS INVENTORY FINDING:

FIND THAT THIS ACTIVITY IS CONSISTENT WITH THE USE CLASSIFICATION DESIGNATED BY THE COMMISSION FOR THE

CALENDAR ITEM NO. C54 (CONT'D)

LAND PURSUANT TO PUBLIC RESOURCES CODE SECTIONS 6370,
ET SEQ.

AUTHORIZATION:

AUTHORIZE ISSUANCE TO THE UNIVERSITY OF SAN FRANCISCO -
ROMBERG TIBURON CENTER FOR ENVIRONMENTAL STUDIES OF A
GENERAL LEASE - PUBLIC AGENCY USE, BEGINNING
JANUARY 1, 2001, FOR A TERM OF FIFTEEN YEARS, FOR THE
CONSTRUCTION, USE, AND MAINTENANCE OF A SALT-WATER
INTAKE PIPELINE, DRAINAGE ROCK, AND RIP-RAP ON THE LAND
SHOWN ON EXHIBIT A ATTACHED AND BY THIS REFERENCE MADE
A PART HEREOF; THE PUBLIC USE AND BENEFIT, WITH THE STATE
RESERVING THE RIGHT AT ANY TIME TO SET A MONETARY RENT
IF THE COMMISSION FINDS SUCH ACTION TO BE IN THE STATE'S
BEST INTEREST.

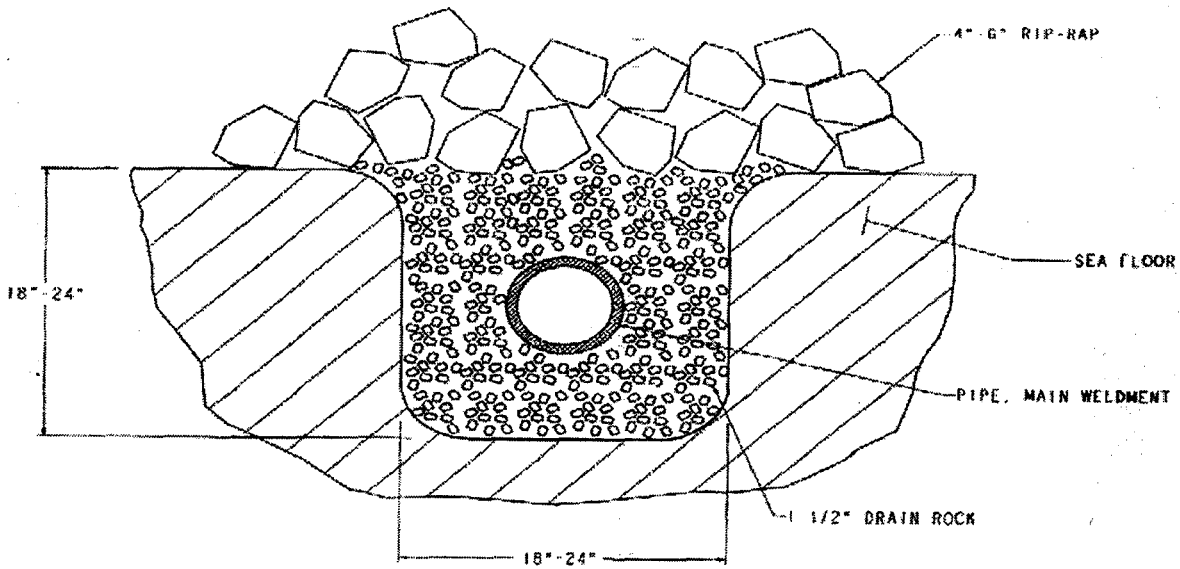
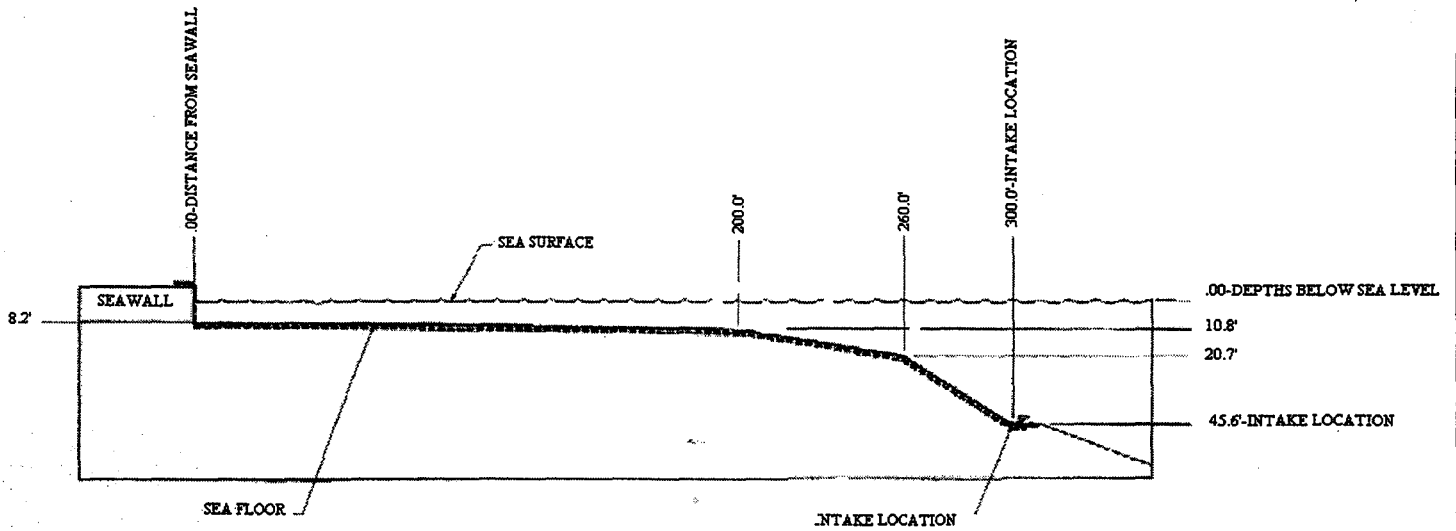

SITE MAP



LOCATION MAP

Exhibit A

W 25676

GL-Public Agency Use

Romberg Tiburon Center

This exhibit is solely for purposes of generally defining the area to be leased, and is not intended to be, nor shall it be construed as, a waiver

limitation of any **600293**
 CALENDAR PAGE
 the subject or other property.
 MINUTE PAGE **6000320**