

MINUTE ITEM

This Calendar Item No. C36 was approved as
Minute Item No. 310 by the California State Lands
Commission by a vote of 3 to 0 at its
11/07/97 meeting.

CALENDAR ITEM

C36

A 67

11/07/97
PRC3855 WP 3855

S 35

H. Maricle

RECREATIONAL PIER LEASE

APPLICANT:

Ernest Fred Grether, Jr., as Trustee of the Community Property Trust, as described in instrument entitled Amended Declaration of Trust - Ernest Fred Grether, Jr. and Margaret Ruth Read Grether, dated February 12, 1981, executed by Ernest Fred Grether, Jr. and Margaret Ruth Read Grether as Trustors
16795 Bolero Lane
Huntington Beach, California 92649

AREA, LAND TYPE, AND LOCATION:

Sovereign lands in Huntington Harbour, city of Huntington Beach, Orange County.

AUTHORIZED USE:

Continued use and maintenance of a boat dock and ramp, as shown on the attached Exhibit A.

LEASE TERM:

Ten years, beginning November 30, 1997.

CONSIDERATION:

No monetary consideration pursuant to Public Resources Code section 6503.5.

SPECIFIC LEASE PROVISIONS:

Liability insurance in the amount of no less than \$300,000.

OTHER PERTINENT INFORMATION:

1. Pursuant to the Commission's delegation of authority and the State CEQA Guidelines (Title 14, California Code of Regulations, section 15061), the staff has determined that this activity is exempt from the requirements of the CEQA as a categorically exempt project. The project is exempt under Class 1, Existing Facilities; Title 2, California Code of Regulations, section 2905 (a) (2).

CALENDAR ITEM NO. C36 (CONT'D)

Authority: Public Resources Code section 21084 and Title 14, California Code of Regulations, section 15300 and Title 2, California Code of Regulations, section 2905.

2. This activity involves lands identified as possessing significant environmental values pursuant to Public Resources Code sections 6370, et seq. Based upon the staff's consultation with the persons nominating such lands and through the CEQA review process, it is the staff's opinion that the project, as proposed, is consistent with its use classification.

EXHIBIT:

A. Land Description

PERMIT STREAMLINING ACT DEADLINE:

N/A

RECOMMENDED ACTION:

IT IS RECOMMENDED THAT THE COMMISSION:

CEQA FINDING:

FIND THAT THE ACTIVITY IS EXEMPT FROM THE REQUIREMENTS OF THE CEQA PURSUANT TO TITLE 14, CALIFORNIA CODE OF REGULATIONS, SECTION 15061, AS A CATEGORICALLY EXEMPT PROJECT, CLASS 1, EXISTING FACILITIES; TITLE 2, CALIFORNIA CODE OF REGULATIONS, SECTION 2905 (a) (2).

SIGNIFICANT LANDS INVENTORY FINDING:

FIND THAT THIS ACTIVITY IS CONSISTENT WITH THE USE CLASSIFICATION DESIGNATED BY THE COMMISSION FOR THE LAND PURSUANT TO PUBLIC RESOURCES CODE SECTIONS 6370, ET SEQ.

AUTHORIZATION:

AUTHORIZE ISSUANCE TO ERNEST FRED GREYER, JR., AS TRUSTEE OF THE COMMUNITY PROPERTY TRUST, AS DESCRIBED IN INSTRUMENT ENTITLED AMENDED DECLARATION OF TRUST - ERNEST FRED GREYER, JR. AND MARGARET RUTH READ GREYER, DATED FEBRUARY 12, 1981, EXECUTED BY ERNEST FRED GREYER, JR. AND MARGARET RUTH READ GREYER AS

CALENDAR ITEM NO. C36 (CONT'D)

TRUSTORS OF A TEN-YEAR RECREATIONAL PIER LEASE,
BEGINNING NOVEMBER 30, 1997, FOR CONTINUED USE AND
MAINTENANCE OF A DOCK AND RAMP AS SHOWN ON EXHIBIT A
ATTACHED AND BY THIS REFERENCE MADE A PART HEREOF; NO
MONETARY CONSIDERATION PURSUANT TO PUBLIC RESOURCES
CODE SECTION 6503.5; LIABILITY INSURANCE IN THE AMOUNT OF
NO LESS THAN \$300,000.

CALENDAR PAGE	216
MINUTE PAGE	010008

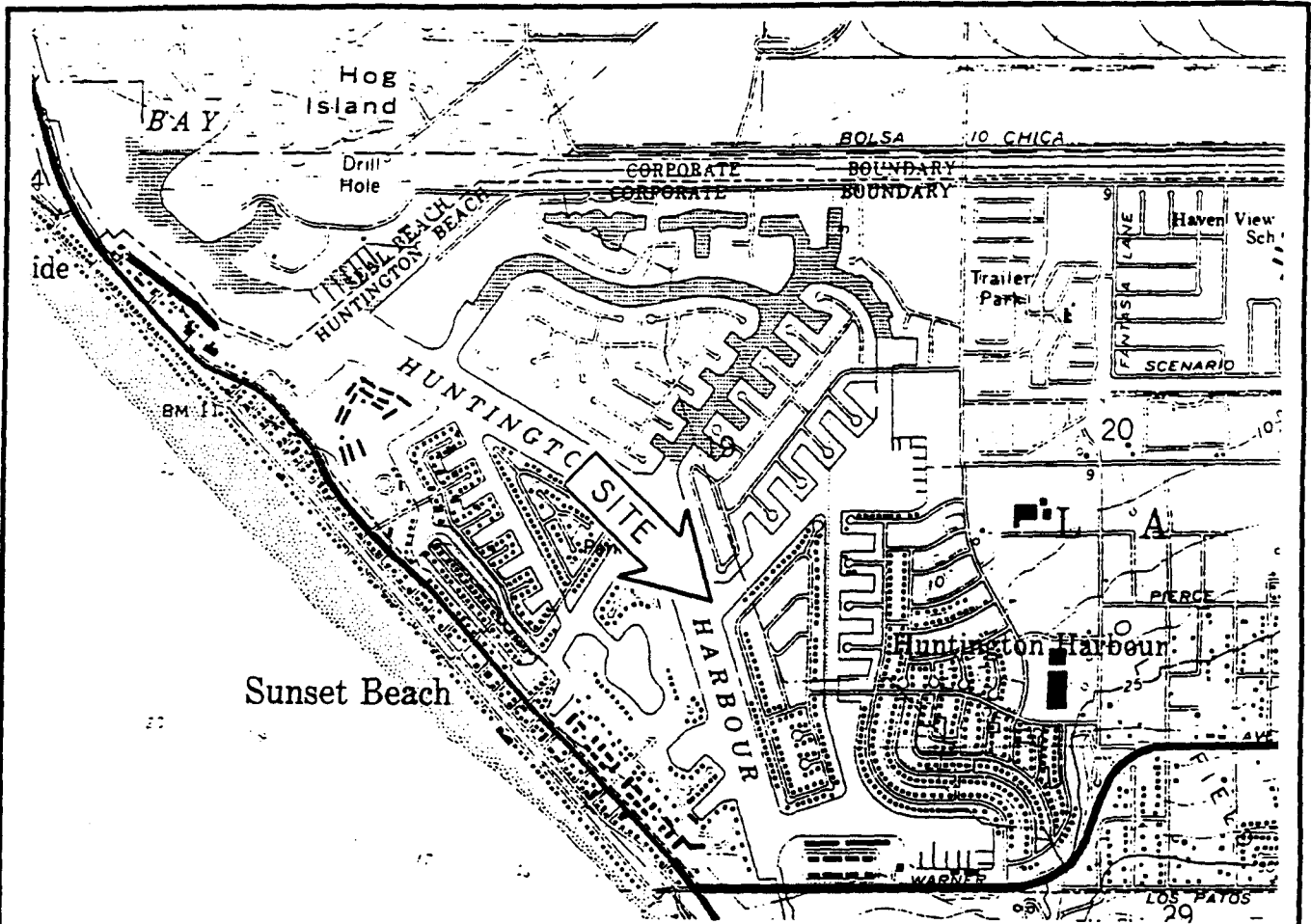

This Exhibit is solely for purposes of generally defining the lease premises and is not intended to be, nor shall it be construed as a waiver or limitation of any State interest in the subject or any other property.

DRAWING NOT TO SCALE

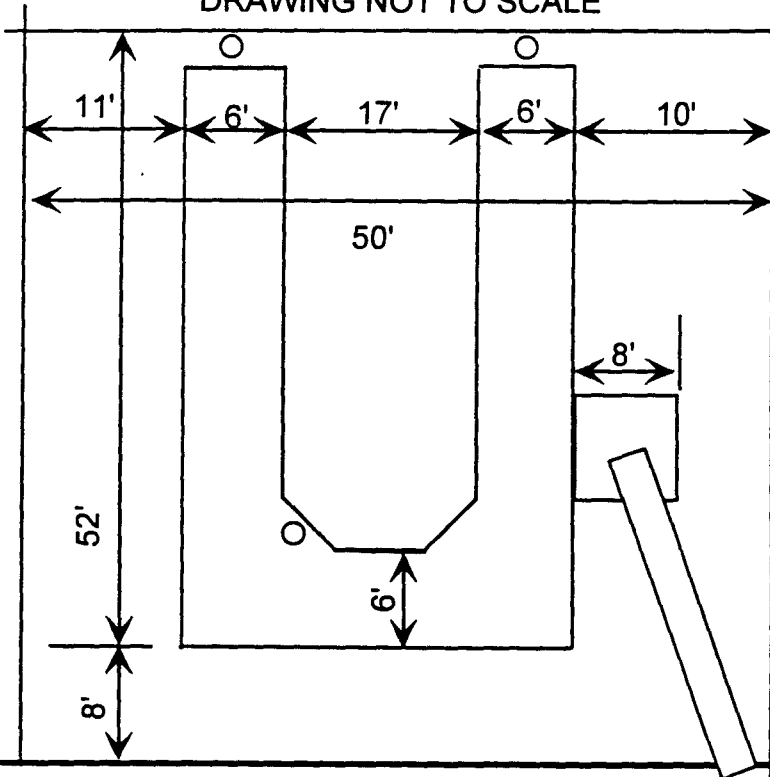
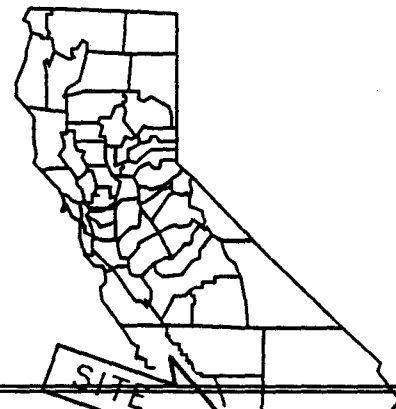

EXHIBIT "A"
 LOCATION MAP - WP3855
 APN 178-371-09
 16795 BOLERO LANE
 HUNTINGTON BEACH
 ORANGE COUNTY, CA.



CALENDAR PAGE 217

MINUTE PAGE

000009