

**MINUTE ITEM**

This Calendar Item No. C45 was approved as Minute Item No. 45 by the California State Lands Commission by a vote of 3 to 0 at its 8/26/97 meeting.

**CALENDAR ITEM**

**C45**

A 67  
S 35

08/26/97  
PRC3176 WP 3176.9  
J. Smith

**RECREATIONAL PIER LEASE**

**APPLICANT:**

J. Robert and Elizabeth L. Meadows  
16482 Somerset Lane  
Huntington Beach, California 92649

**AREA, LAND TYPE, AND LOCATION:**

Sovereign lands in Huntington Harbour, Huntington Beach, Orange County.

**AUTHORIZED USE:**

Reconstruction and continued use and maintenance of existing boat dock, as shown on attached Exhibit A.

**LEASE TERM:**

Ten years, beginning August 1, 1997.

**CONSIDERATION:**

No monetary consideration pursuant to Public Resources Code section 6503.5.

**SPECIFIC LEASE PROVISIONS:**

Liability insurance in the amount of no less than \$300,000.

**OTHER PERTINENT INFORMATION:**

1. Pursuant to the Commission's delegation of authority and the State CEQA Guidelines (Title 14, California Code of Regulations, section 15061), the staff has determined that this activity is exempt from the requirements of the CEQA as a categorically exempt project. The project is exempt under Class 2, Replacement or Reconstruction; Title 2, California Code of Regulations, section 2905(b).

Authority: Public Resources Code, section 21084 and Title 14, California Code of Regulations, section 15300 and Title 2, California Code of Regulations, section 2905.

CALENDAR PAGE	230
MINUTE PAGE	001905

CALENDAR ITEM NO. C45 (CONT'D)

2. This activity involves lands identified as possessing significant environmental values pursuant to Public Resources Code sections 6370, et seq. Based upon the staff's consultation with the persons nominating such lands and through the CEQA review process, it is the staff's opinion that the project, as proposed, is consistent with its use classification.

**EXHIBIT:**

- A. Location and Site Map.

**PERMIT STREAMLINING ACT DEADLINE:**

N/A

**RECOMMENDED ACTION:**

IT IS RECOMMENDED THAT THE COMMISSION:

**CEQA FINDING:**

FIND THAT THE ACTIVITY IS EXEMPT FROM THE REQUIREMENTS OF THE CEQA PURSUANT TO TITLE 14, CALIFORNIA CODE OF REGULATIONS, SECTION 15061 AS A CATEGORICALLY EXEMPT PROJECT, CLASS 2, REPLACEMENT OR RECONSTRUCTION; TITLE 2, CALIFORNIA CODE OF REGULATIONS, SECTION 2905 (b).

**SIGNIFICANT LANDS INVENTORY FINDING:**

FIND THAT THIS ACTIVITY IS CONSISTENT WITH THE USE CLASSIFICATION DESIGNATED BY THE COMMISSION FOR THE LAND PURSUANT TO PUBLIC RESOURCES CODE SECTIONS 6370, ET SEQ.

**AUTHORIZATION:**

AUTHORIZE ISSUANCE TO J. ROBERT AND ELIZABETH L. MEADOWS OF A TEN-YEAR RECREATIONAL PIER LEASE, BEGINNING AUGUST 1, 1997, FOR RECONSTRUCTION AND CONTINUED USE AND MAINTENANCE OF AN EXISTING BOAT DOCK ON THE LAND SHOWN ON EXHIBIT A ATTACHED AND BY THIS REFERENCE MADE A PART HEREOF; NO MONETARY CONSIDERATION PURSUANT TO PUBLIC RESOURCES CODE SECTION 6503.5; LIABILITY INSURANCE IN THE AMOUNT OF NO LESS THAN \$300,000.

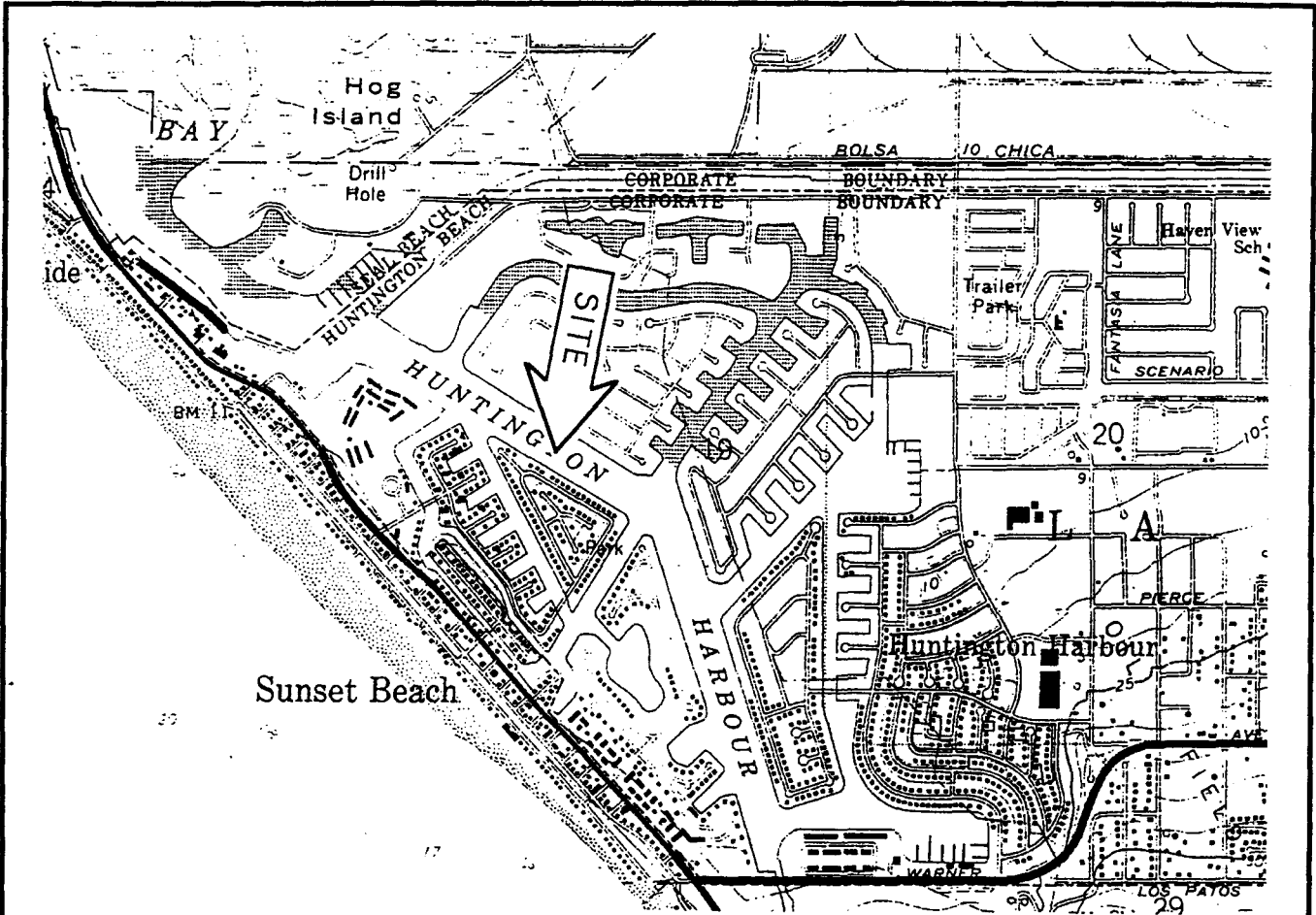

This Exhibit is solely for purposes of generally defining the lease premises and is not intended to be, nor shall it be construed as a waiver or limitation of any State interest in the subject or any other property.

**APN 178-411-12**

DRAWING NOT TO SCALE

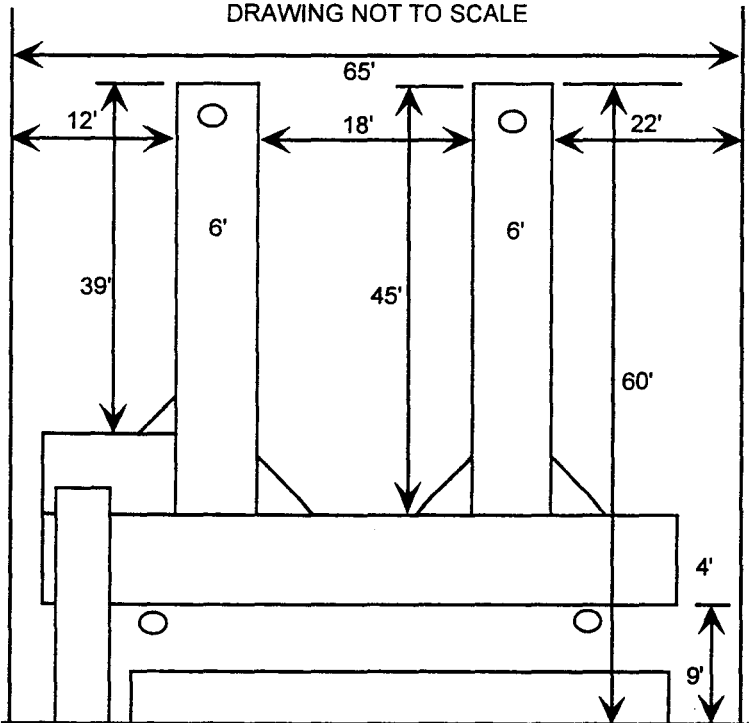

EXHIBIT "A"  
LOCATION MAP  
WP 3176.9

16482 SOMERSET LANE  
HUNTINGTON BEACH  
ORANGE COUNTY, CA.



MINUTE PAGE 001907