

MINUTE ITEM

This Calendar Item No. C35 was approved as Minute Item No. 35 by the California State Lands Commission by a vote of 3 to 0 at its 8/26/97 meeting.

**CALENDAR ITEM
C35**

A 4
S 1

08/26/97
PRC 3652.9
J. Ludlow

RECREATIONAL PIER LEASE

APPLICANT:

Clyde R. Gibb and Donna Joan Gibb as Trustees of the Gibb 1992 Trust U/D.T dated August 25, 1992 and Bruce J. Pohle and Sharon Pohle, Trustees of the Bruce J. Pohle and Sharon Pohle 1970 Revocable Trust
P.O. Box 412
Carnelian Bay, California 96140

AREA, LAND TYPE, AND LOCATION:

Sovereign lands in Lake Tahoe, Carnelian Bay, Placer County.

AUTHORIZED USE:

Continued use and maintenance of an existing joint-use pier, two boat lifts and four mooring buoys.

LEASE TERM:

Ten years, beginning September 1, 1996.

CONSIDERATION:

No monetary consideration pursuant to Public Resources Code section 6503.5.

SPECIFIC LEASE PROVISIONS:

Insurance:

Liability insurance in the amount of no less than \$300,000.

Other:

The lease is conditioned on lessee obtaining authorization from the Tahoe Regional Planning Agency for the mooring buoys within two years from the effective date of the authorization of the buoys by the Commission.

OTHER PERTINENT INFORMATION:

1. Pursuant to the Commission's delegation of authority and the State CEQA Guidelines (Title 14, California Code of Regulations, section 15061), the staff has determined that this activity is exempt from the requirements of the CEQA as a categorically exempt project. The project is exempt under

CALENDAR PAGE	165
MINUTE PAGE	001839

CALENDAR ITEM NO. C35 (CONT'D)

Class 1, Existing Facilities; Title 2, California Code of Regulations, section 2905 (a) (2). Authority: Public Resources Code section 21084 and Title 14, California Code of Regulations, section 15300 and Title 2, California Code of Regulations, section 2905.

2. This activity involves lands identified as possessing significant environmental values pursuant to Public Resources Code sections 6370, et seq. Based upon the staff's consultation with the persons nominating such lands and through the CEQA review process, it is the staff's opinion that the project, as proposed, is consistent with its use classification.

FURTHER APPROVALS REQUIRED:

Tahoe Regional Planning Agency, California State Lands Commission

EXHIBITS:

- A. Site and Location Map

PERMIT STREAMLINING ACT DEADLINE:

N/A

RECOMMENDED ACTION:

IT IS RECOMMENDED THAT THE COMMISSION:

CEQA FINDING:

FIND THAT THE ACTIVITY IS EXEMPT FROM THE REQUIREMENTS OF THE CEQA PURSUANT TO TITLE 14, CALIFORNIA CODE OF REGULATIONS, SECTION 15061, AS A CATEGORICALLY EXEMPT PROJECT, CLASS 1, EXISTING FACILITIES; TITLE 2, CALIFORNIA CODE OF REGULATIONS, SECTION 2905 (a) (2).

SIGNIFICANT LANDS INVENTORY FINDING:

FIND THAT THIS ACTIVITY IS CONSISTENT WITH THE USE CLASSIFICATION DESIGNATED BY THE COMMISSION FOR THE LAND PURSUANT TO PUBLIC RESOURCES CODE SECTIONS 6370, ET SEQ.

CALENDAR ITEM NO. C35 (CONT'D)

AUTHORIZATION:

AUTHORIZE ISSUANCE TO CLYDE R. GIBB AND DONNA JOAN GIBB AS TRUSTEES OF THE GIBB 1992 TRUST U/D.T DATED AUGUST 25, 1992 AND BRUCE J. POHLE AND SHARON POHLE, TRUSTEES OF THE BRUCE J. POHLE AND SHARON POHLE 1970 REVOCABLE TRUST OF A TEN-YEAR RECREATIONAL PIER LEASE, BEGINNING SEPTEMBER 1, 1996 FOR THE CONTINUED USE AND MAINTENANCE OF AN EXISTING JOINT-USE PIER, TWO BOAT LIFTS AND FOUR MOORING BUOYS ON THE LAND SHOWN ON EXHIBIT A ATTACHED AND BY THIS REFERENCE MADE A PART HEREOF; NO MONETARY CONSIDERATION PURSUANT TO PUBLIC RESOURCES CODE SECTION 6503.5; LIABILITY INSURANCE IN THE AMOUNT OF NO LESS THAN \$300,000.

CALENDAR PAGE	167
MINUTE PAGE	001841

NO SCALE

SITE MAP

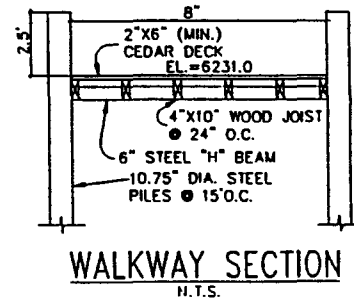
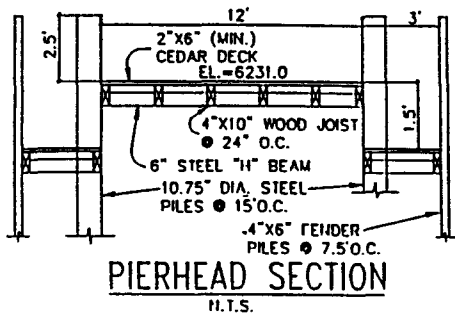
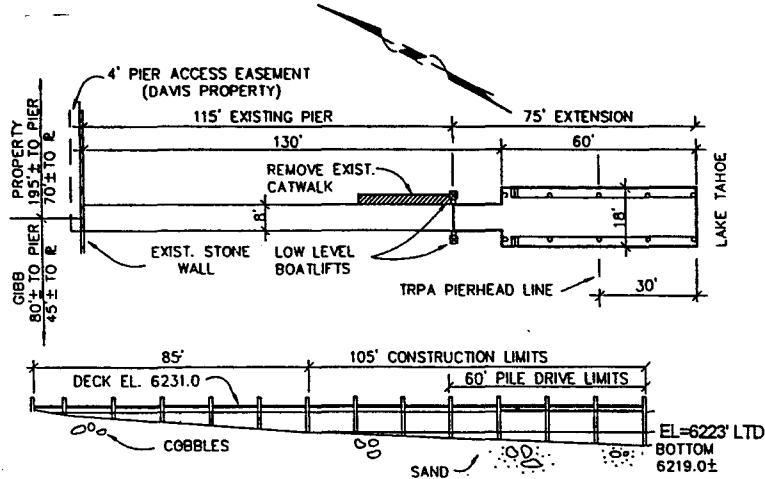

4170 and 4176 Ferguson Ave.

NO SCALE

LOCATION MAP

Lake Tahoe

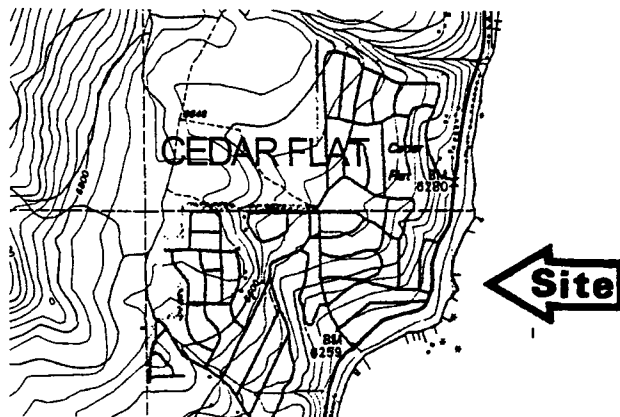
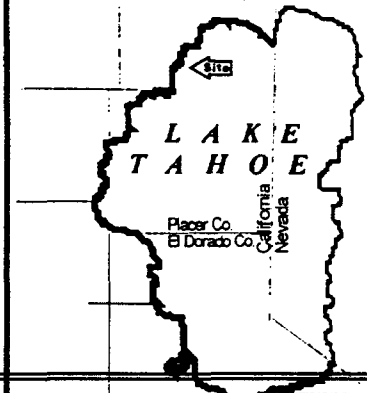

Exhibit A
 PRC 3652.9
 APNs 092-200-025,026
 Lake Tahoe
 PLACER COUNTY
 Sheet 1 of 2



This Exhibit is solely for purposes of generally defining the lease premises, and is not intended to be, nor shall it be construed as, a waiver or limitation of any State interest in the subject or any other property.

CALENDAR PAGE 168

MINUTE PAGE 001842

NO SCALE

SITE MAP

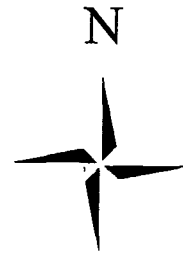
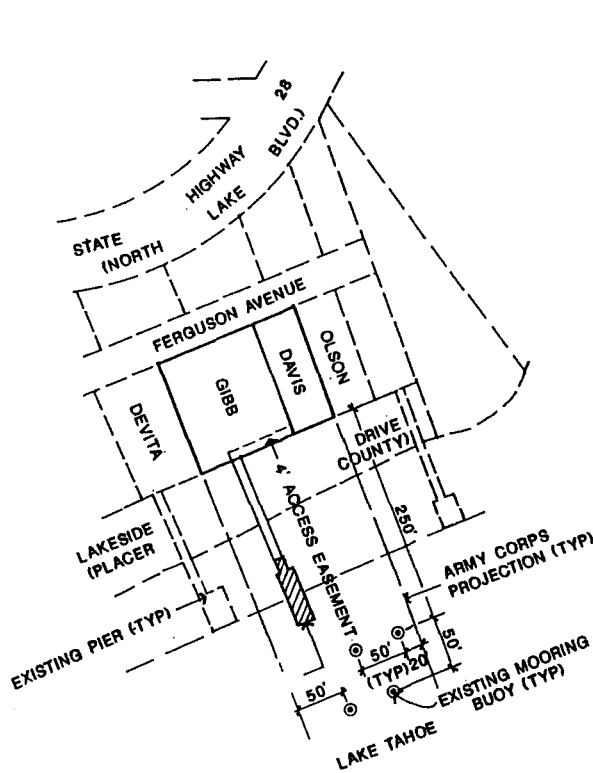

4170 and 4176 Ferguson Ave.

NO SCALE

LOCATION MAP

Lake Tahoe

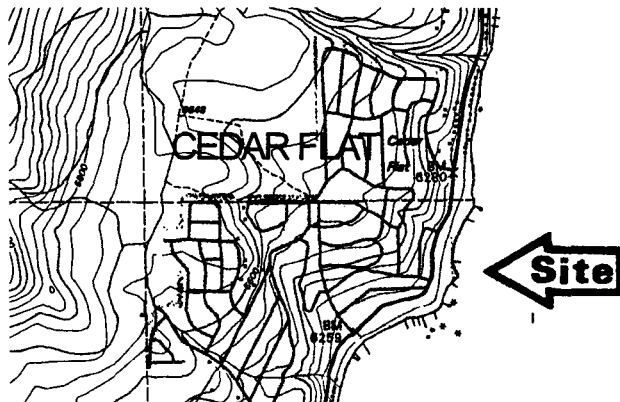
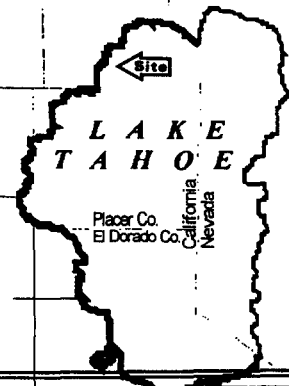

Exhibit A
 PRC 3652.9
 APNs 092-200-025,026
 Lake Tahoe
 PLACER COUNTY
 Sheet 2 of 2



This Exhibit is solely for purposes of generally defining the lease premises, and is not intended to be, nor shall it be construed as, a waiver or limitation of any State interest in the subject or any other property.

CALENDAR PAGE 169

MINUTE PAGE 001843