

MINUTE ITEM

This Calendar Item No. C68 was approved as Minute Item No. 68 by the California State Lands Commission by a vote of 3 to 0 at its 5/12/97 meeting.

**CALENDAR ITEM
C68**

A 4
S 1

05/12/97
W 21090
B. Young

RECREATIONAL PIER LEASE

LESSEE:

Charles E. McCarl and Suzanne McCarl Family Trust
Charles E. McCarl and Suzanne McCarl, Trustees
P.O. Box 9
Williams, California 95987

AREA, LAND TYPE, AND LOCATION:

Submerged lands in Lake Tahoe, Camp Richardson, El Dorado County.

AUTHORIZED USE:

Use and maintenance of a pier and two mooring buoys, as shown on the attached Exhibit A.

LEASE TERM:

Ten years, beginning May 1, 1997.

CONSIDERATION:

No monetary consideration pursuant to Public Resources Code section 6503.5.

SPECIFIC LEASE PROVISIONS:

Insurance:

Liability insurance with coverage of no less than \$300,000.

Other:

The lease is conditioned on lessee's obtaining authorization from the Tahoe Regional Planning Agency for the existing buoys within two years of the authorization of the buoys by the Commission.

OTHER PERTINENT INFORMATION:

1. Pursuant to the Commission's delegation of authority and the State CEQA Guidelines (Title 14, California Code of Regulations, section 15061),

CALENDAR PAGE	336
MINUTE PAGE	000831

CALENDAR ITEM NO. C68 (CONT'D)

the staff has determined that this activity is exempt from the requirements of the CEQA as a categorically exempt project. The project is exempt under Class 3, Construction of Small Structures; Title 2, California Code of Regulations, section 2905 (c) (1) (pier) and section 2905 (c) (3) (buoys).

Authority: Public Resources Code section 21084 and Title 14, California Code of Regulations, section 15300 and Title 2, California Code of Regulations, section 2905.

2. This activity involves lands identified as possessing significant environmental values pursuant to Public Resources Code sections 6370, et seq. Based upon the staff's consultation with the persons nominating such lands and through the CEQA review process, it is the staff's opinion that the project, as proposed, is consistent with its use classification.

EXHIBIT:

- A. Site and Location Map

PERMIT STREAMLINING ACT DEADLINE:

N/A

RECOMMENDED ACTION:

IT IS RECOMMENDED THAT THE COMMISSION:

CEQA FINDING:

FIND THAT THE ACTIVITY IS EXEMPT FROM THE REQUIREMENTS OF THE CEQA PURSUANT TO TITLE 14, CALIFORNIA CODE OF REGULATIONS, SECTION 15061 AS A CATEGORICALLY EXEMPT PROJECT, CLASS 3, CONSTRUCTION OF SMALL STRUCTURES; TITLE 2, CALIFORNIA CODE OF REGULATIONS, SECTION 2905 (c) (1) (PIER) AND SECTION 2905 (c) (3) (BUOYS).

SIGNIFICANT LANDS INVENTORY FINDING:

FIND THAT THIS ACTIVITY IS CONSISTENT WITH THE USE CLASSIFICATION DESIGNATED BY THE COMMISSION FOR THE LAND PURSUANT TO PUBLIC RESOURCES CODE SECTIONS 6370, ET SEQ.

CALENDAR ITEM NO. C68 (CONT'D)

AUTHORIZATION:

AUTHORIZE ISSUANCE TO CHARLES E. MCCARL AND SUZANNE MCCARL FAMILY TRUST; CHARLES E. MCCARL AND SUZANNE MCCARL, TRUSTEES OF A TEN-YEAR RECREATIONAL PIER LEASE BEGINNING MAY 1, 1997, FOR A PIER AND TWO MOORING BUOYS ON THE LANDS SHOWN ON EXHIBIT A ATTACHED AND BY THIS REFERENCE MADE A PART HEREOF; NO MONETARY CONSIDERATION PURSUANT TO PUBLIC RESOURCES CODE SECTION 6503.5; LIABILITY INSURANCE WITH COVERAGE OF NO LESS THAN \$300,000.

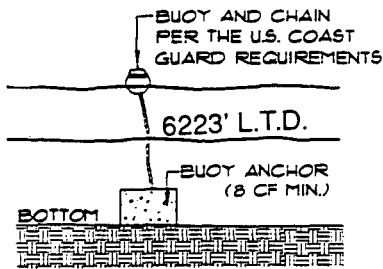
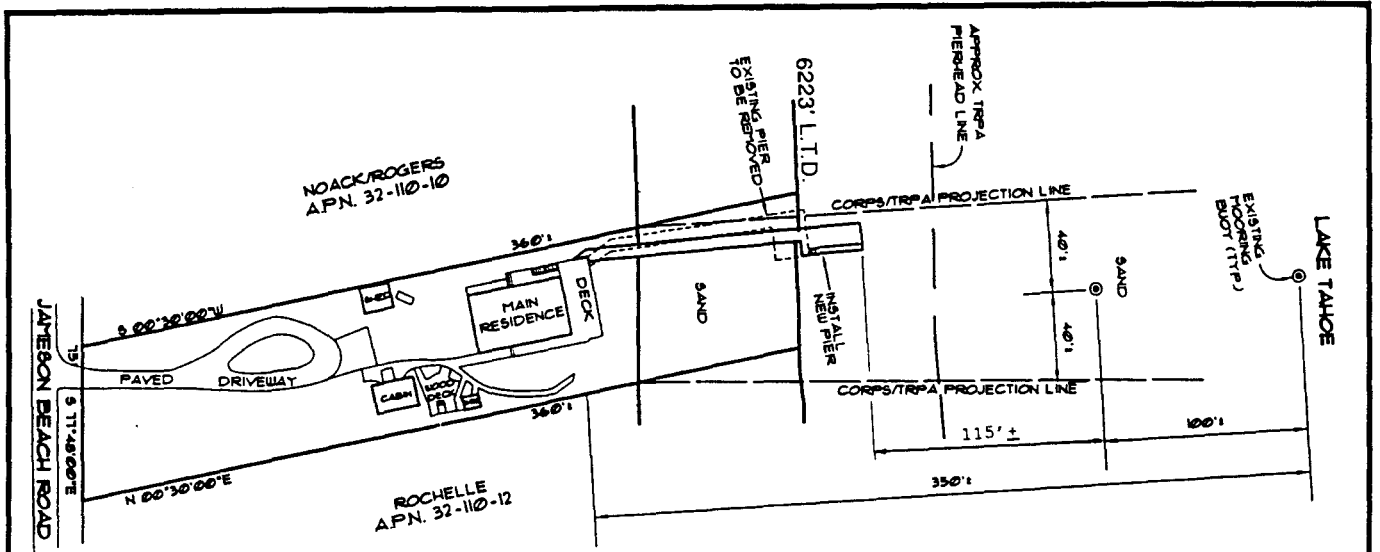

BUOY DETAIL
NO SCALE

3047 Jameson Beach Rd.

NO SCALE

LOCATION MAP
LAKE TAHOE

NO SCALE

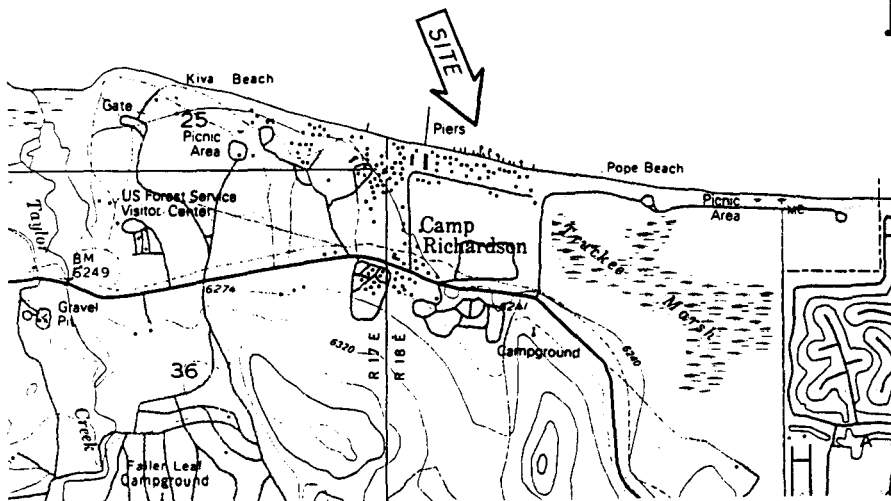

This Exhibit is solely for purposes of generally defining the lease premises, and is not intended to be, nor shall it be construed as, a waiver or limitation of any State interest in the subject or any other property.

Exhibit A

W 21090

APN 32 - 110 - 11

Lake Tahoe

EL DORADO COUNTY
Sheet 1 of 2 Sheets

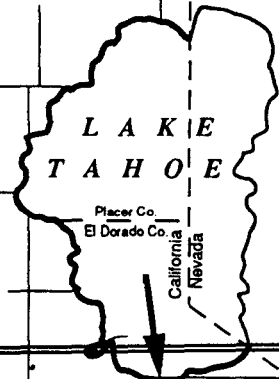

CALENDAR PAGE

339

MINUTE PAGE

000804

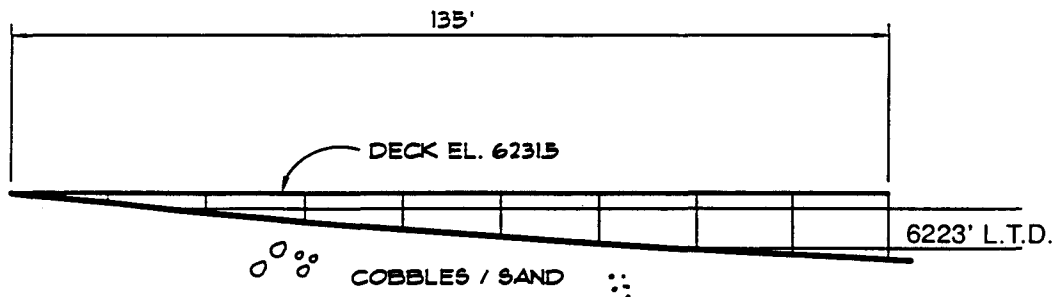
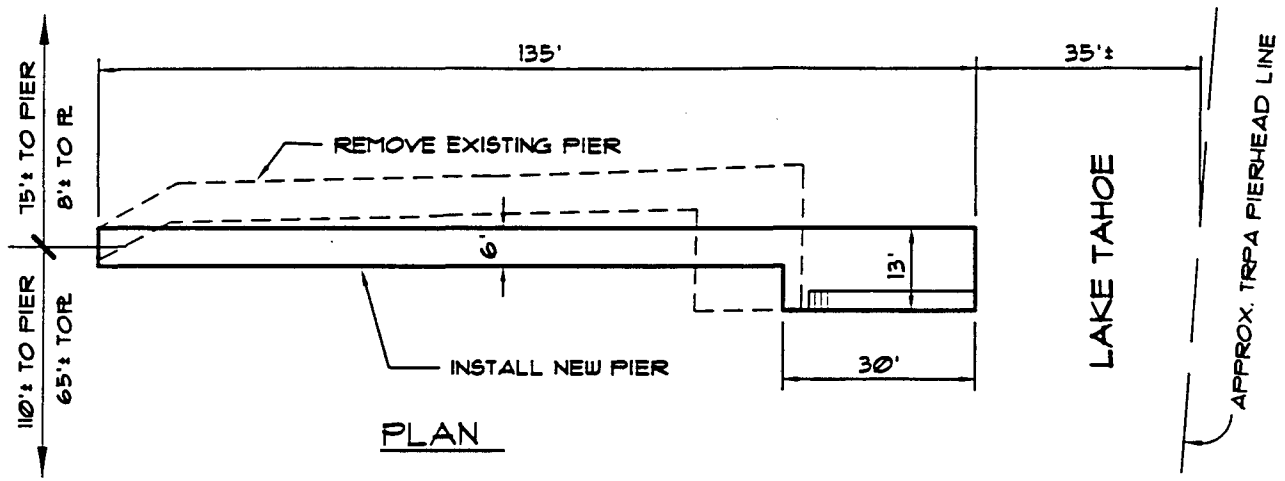

PROFILE

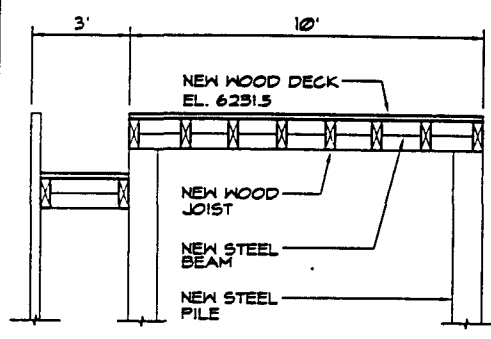

TYPICAL PIERHEAD SECTION
NO SCALE

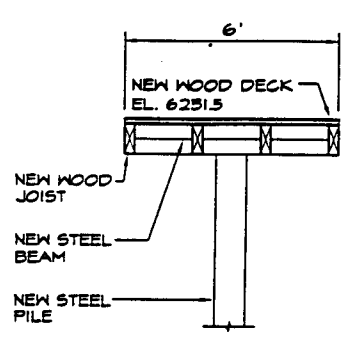

TYPICAL PIER WALKWAY
NO SCALE

NO SCALE

Exhibit A
W 21090
APN 32 - 110 - 11
Lake Tahoe
EL DORADO COUNTY
Sheet 2 of 2 Sheets

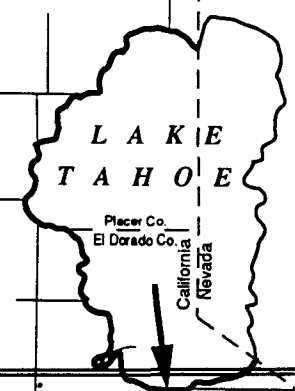

This Exhibit is solely for purposes of generally defining the lease premises, and is not intended to be, nor shall it be construed as, a waiver or limitation of any State interest in the subject or any other property.