

MINUTE ITEM

This Calendar Item No. C34 was approved as Minute Item No. 34 by the California State Lands Commission by a vote of 3 to 0 at its 5/12/97 meeting.

CALENDAR ITEM

C34

A 4
S 1

05/12/97
PRC 6937.9
J. Ludlow

RECREATIONAL PIER LEASE

LESSEE:

John P. Geyer and Delores G. Geyer, Co-Trustees of the Geyer Family Trust dated March 28, 1977
2513 Biltmore Drive
Alamo, California 94507-2300

AREA, LAND TYPE, AND LOCATION:

Submerged lands in Lake Tahoe near Tahoe City, Placer County.

AUTHORIZED USE:

Continued use and maintenance of an existing pier and boat lift, as shown on the attached Exhibit A.

LEASE TERM:

Ten years, beginning April 1, 1997.

CONSIDERATION:

No monetary consideration pursuant to Public Resources Code section 6503.5.

SPECIFIC LEASE PROVISIONS:

Insurance:

Liability insurance in the amount of no less than \$300,000.

OTHER PERTINENT INFORMATION:

1. Pursuant to the Commission's delegation of authority and the State CEQA Guidelines (Title 14, California Code of Regulations, section 15061), the staff has determined that this activity is exempt from the requirements of the CEQA as a categorically exempt project. The project is exempt under Class 1, Existing Facilities; Title 2, California Code of Regulations, section 2905 (a) (2). Authority: Public Resources Code section 21084 and Title 14, California Code of Regulations, section 15300 and Title 2, California Code of Regulations, section 2905.

CALENDAR PAGE	196
MINUTE PAGE	000689

CALENDAR ITEM NO. C34 (CONT'D)

2. This activity involves lands identified as possessing significant environmental values pursuant to Public Resources Code sections 6370, et seq. Based upon the staff's consultation with the persons nominating such lands and through the CEQA review process, it is the staff's opinion that the project, as proposed, is consistent with its use classification.

EXHIBIT:

- A. Site and Location Map

PERMIT STREAMLINING ACT DEADLINE:

N/A

RECOMMENDED ACTION:

IT IS RECOMMENDED THAT THE COMMISSION:

CEQA FINDING:

FIND THAT THE ACTIVITY IS EXEMPT FROM THE REQUIREMENTS OF THE CEQA PURSUANT TO TITLE 14, CALIFORNIA CODE OF REGULATIONS, SECTION 15061 AS A CATEGORICALLY EXEMPT PROJECT, CLASS 1, EXISTING FACILITIES; TITLE 2, CALIFORNIA CODE OF REGULATIONS, SECTION 2905 (a) (2).

SIGNIFICANT LANDS INVENTORY FINDING:

FIND THAT THIS ACTIVITY IS CONSISTENT WITH THE USE CLASSIFICATION DESIGNATED BY THE COMMISSION FOR THE LAND PURSUANT TO PUBLIC RESOURCES CODE SECTIONS 6370, ET SEQ.

AUTHORIZATION:

AUTHORIZE ISSUANCE TO JOHN P. GEYER AND DELORES G. GEYER, CO-TRUSTEES OF THE GEYER FAMILY TRUST DATED MARCH 28, 1977, OF A TEN-YEAR RECREATIONAL PIER LEASE BEGINNING APRIL 1, 1997, FOR A PIER AND BOAT LIFT ON THE LANDS SHOWN ON EXHIBIT A ATTACHED AND BY THIS REFERENCE MADE A PART HEREOF; NO MONETARY CONSIDERATION PURSUANT TO PUBLIC RESOURCES CODE SECTION 6503.5; LIABILITY INSURANCE WITH COVERAGE OF NO LESS THAN \$300,000.

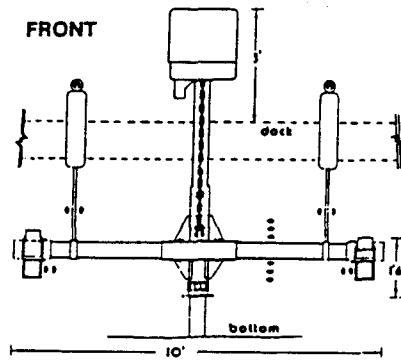
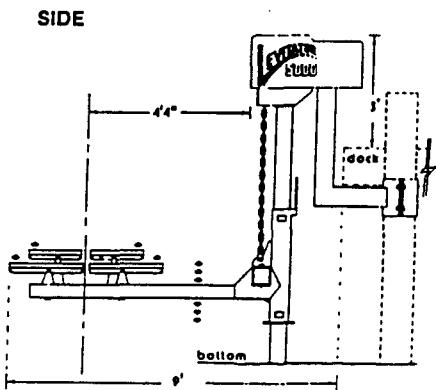
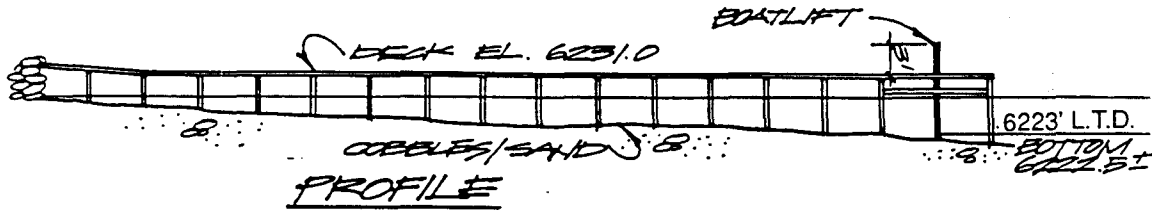
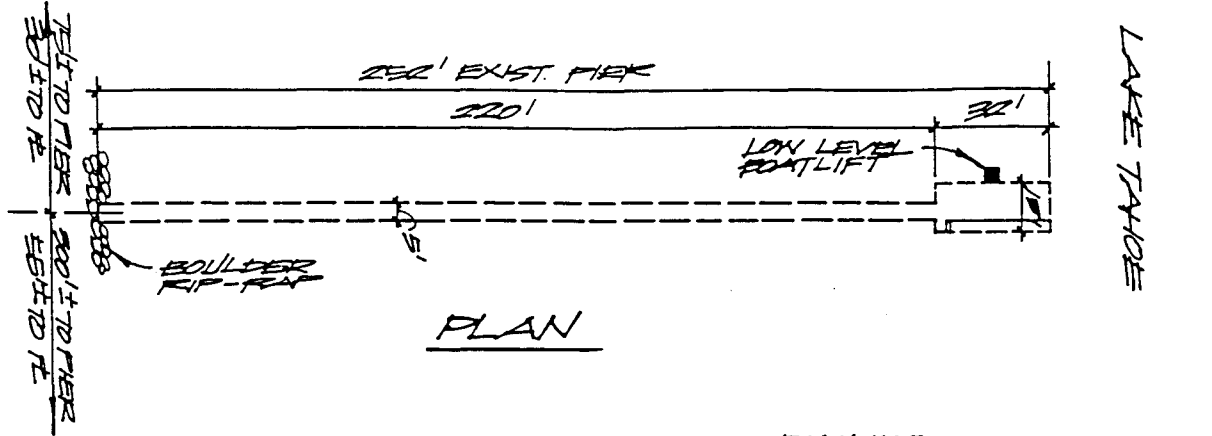

1040 West Lake Blvd.

NO SCALE

LOCATION MAP

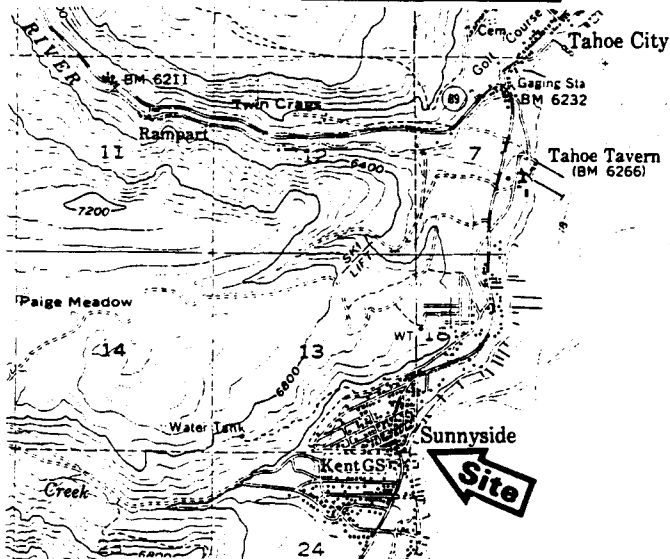

NO SCALE

Exhibit A
 PRC 6937.9
 APN 83 - 183 - 004
 Lake Tahoe
 PLACER COUNTY

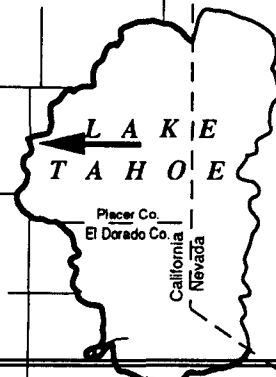

This Exhibit is solely for purposes of generally defining the lease premises, and is not intended to be, nor shall it be construed as, a waiver or limitation of any State interest in the subject or any other property.

CALENDAR PAGE 198

MINUTE PAGE 000691