

MINUTE ITEM  
This Calendar Item No. C55  
was approved as Minute Item  
No. 55 by the State Lands  
Commission by a vote of 3  
to 0 at its 02/12/97  
meeting.

CALENDAR ITEM  
**C55**

A 70  
S 35

02/12/97  
PRC3565 WP 3565.9  
J. Smith

**RECREATIONAL PIER LEASE**

**LESSEE:**

Virginia L. Baker  
3282 Gilbert Drive  
Huntington Beach, California 92649

**AREA, LAND TYPE, AND LOCATION:**

Submerged lands in Huntington Harbour, Orange County.

**AUTHORIZED USE:**

Continued use and maintenance of boat dock, as shown on Exhibit "A",  
attached.

**LEASE TERM:**

Ten years, beginning March 1, 1997.

**CONSIDERATION:**

No monetary consideration pursuant to Public Resources Code section 6503.5.

**SPECIFIC LEASE PROVISIONS:**

Insurance:

Liability insurance in the amount of no less than \$300,000.

**EXHIBIT:**

A. Site Map

**PERMIT STREAMLINING ACT DEADLINE:**

N/A

**RECOMMENDED ACTION:**

IT IS RECOMMENDED THAT THE COMMISSION:

CALENDAR ITEM NO. **C55** (CONT'D)

**CEQA FINDING:**

FIND THAT THE ACTIVITY IS EXEMPT FROM THE REQUIREMENTS OF THE CEQA PURSUANT TO TITLE 14, CALIFORNIA CODE OF REGULATIONS, SECTION 15061 AS A CATEGORICALLY EXEMPT PROJECT, CLASS 1, EXISTING FACILITIES, TITLE 2, CALIFORNIA CODE OF REGULATIONS, SECTION 2905(a)(2).

**SIGNIFICANT LANDS INVENTORY FINDING:**

FIND THAT THIS ACTIVITY IS CONSISTENT WITH THE USE CLASSIFICATION DESIGNATED FOR THE LAND PURSUANT TO PUBLIC RESOURCES CODE SECTIONS 6370, ET SEQ.

**AUTHORIZATION:**

AUTHORIZE ISSUANCE TO VIRGINIA L. BAKER OF A 10-YEAR RECREATIONAL PIER LEASE, EFFECTIVE MARCH 1, 1997; NO MONETARY CONSIDERATION PURSUANT TO PUBLIC RESOURCES CODE SECTION 6503.5, PROVISION FOR LIABILITY INSURANCE IN THE AMOUNT OF NO LESS THAN \$300,000; FOR THE CONTINUED USE AND MAINTENANCE OF A BOAT DOCK IN HUNTINGTON HARBOUR, ORANGE COUNTY, ON THE LAND DESCRIBED ON EXHIBIT "A" ATTACHED AND BY REFERENCE MADE A PART HEREOF.

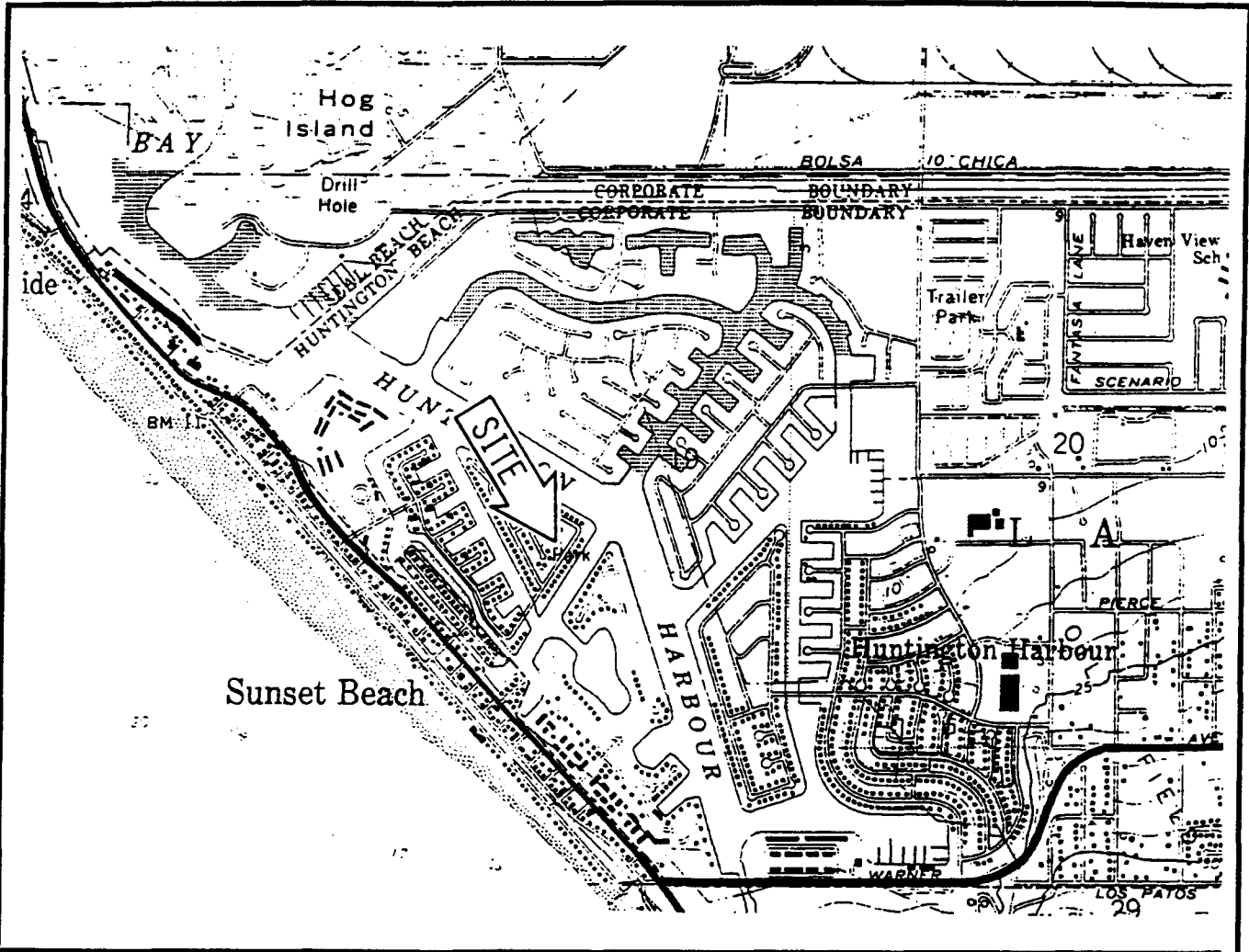

LOT 10 TRACT 4677-- APN 178-421-33

EXISTING BULKHEAD

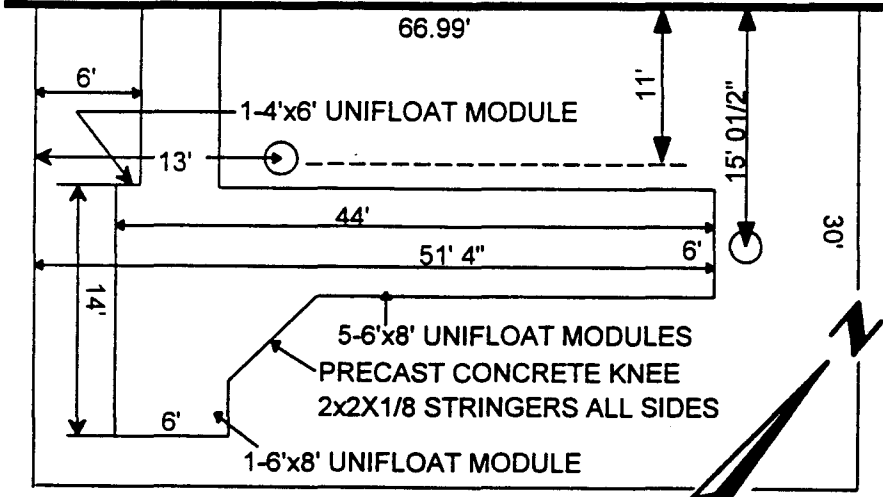

This Exhibit is solely for purposes of generally defining the lease premises, and is not intended to be, nor shall it be construed as, a waiver or limitation of any State interest in the subject or any other property.

EXHIBIT "A"

SITE MAP WP3565  
 3282 GILBERT DRIVE  
 HUNTINGTON BEACH, CA.  
 ORANGE COUNTY



SITE CALENDAR PAGE 252

MINUTE PAGE 000276