

MINUTE ITEM
This Calendar Item No. C42
was approved as Minute Item
No. 42 by the State Lands
Commission by a vote of 3
to 0 at its 02/12/97
meeting.

CALENDAR ITEM
C42

A 4
S 1

02/12/97
PRC 4483.9
J. Ludlow

RECREATIONAL PIER LEASE

LESSEE:

John H. Bottomley III, Trustee and Marion W. Bottomley, Trustee of the John H. Bottomley and Marion W. Bottomley Trust Agreement dated October 27, 1980
6 Mira Loma
Orinda, California 94563-2313

AREA, LAND TYPE, AND LOCATION:

Sovereign lands in Lake Tahoe at Carnelian Bay, Placer County.

AUTHORIZED USE:

Proposed pier reconstruction and expansion, installation of a boat lift, new catwalk and retention of an existing buoy, as shown on the attached Exhibit "A".

LEASE TERM:

Ten years, beginning February 1, 1997.

CONSIDERATION:

No monetary consideration pursuant to Public Resources Code section 6503.5.

SPECIFIC LEASE PROVISIONS:

Insurance:

Liability insurance in the amount of no less than \$300,000.

OTHER PERTINENT INFORMATION:

The lease is conditioned on Lessee obtaining authorization from the Tahoe Regional Planning Agency for the existing buoy within two years of the effective date of the authorization of the buoy by the Commission.

APPROVALS OBTAINED:

Tahoe Regional Planning Agency, United States Army Corps of Engineers

CALENDAR ITEM NO. C42 (CONT'D)

FURTHER APPROVALS REQUIRED:

Placer County, California Department of Fish and Game, California State Lands Commission

EXHIBITS:

A. Site and Location Map

PERMIT STREAMLINING ACT DEADLINE:

February 18, 1997

RECOMMENDED ACTION:

IT IS RECOMMENDED THAT THE COMMISSION:

CEQA FINDING:

AS TO THE PIER: FIND THAT THE ACTIVITY IS EXEMPT FROM THE REQUIREMENTS OF THE CEQA PURSUANT TO TITLE 14, CALIFORNIA CODE OF REGULATIONS, SECTION 15061 AS A CATEGORICALLY EXEMPT PROJECT, CLASS 1, EXISTING FACILITIES; TITLE 14, CALIFORNIA CODE OF REGULATIONS, SECTION 15301(e).

AS TO THE BOATLIFT: FIND THAT THE ACTIVITY IS EXEMPT FROM THE REQUIREMENTS OF THE CEQA PURSUANT TO TITLE 14, CALIFORNIA CODE OF REGULATIONS, SECTION 15061 AS A CATEGORICALLY EXEMPT PROJECT, CLASS 3, NEW CONSTRUCTION OF SMALL STRUCTURES; TITLE 14, CALIFORNIA CODE OF REGULATIONS, SECTION 15303 (e).

AS TO THE BUOY: FIND THAT THE ACTIVITY IS EXEMPT FROM THE REQUIREMENTS OF THE CEQA PURSUANT TO TITLE 14, CALIFORNIA CODE OF REGULATIONS, SECTION 15061 AS A CATEGORICALLY EXEMPT PROJECT, CLASS 3, NEW CONSTRUCTION OF SMALL STRUCTURES; TITLE 2, CALIFORNIA CODE OF REGULATIONS, SECTION 2905 (c)(3).

SIGNIFICANT LANDS INVENTORY FINDING:

FIND THAT THIS ACTIVITY IS CONSISTENT WITH THE USE CLASSIFICATION DESIGNATED BY THE COMMISSION FOR THE LAND PURSUANT TO PUBLIC RESOURCES CODE SECTIONS 6370, ET SEQ.

CALENDAR ITEM NO. C42 (CONT'D)

AUTHORIZATION:

AUTHORIZE TO JOHN H. BOTTOMLEY III, TRUSTEE AND MARION W. BOTTOMLEY, TRUSTEE OF THE JOHN H. BOTTOMLEY AND MARION W. BOTTOMLEY TRUST AGREEMENT DATED OCTOBER 27, 1980 OF A TEN-YEAR RECREATIONAL PIER LEASE BEGINNING FEBRUARY 1, 1997; FOR ALL OF THE STATE'S SOVEREIGN LANDS BELOW THE ELEVATION OF 6223 FEET, LAKE TAHOE DATUM, UNDER APPLICANT'S PIER AS DEPICTED ON EXHIBIT "A" ATTACHED AND BY REFERENCE MADE A PART HEREOF; NO MONETARY CONSIDERATION PURSUANT TO PUBLIC RESOURCES CODE SECTION 6503.5.

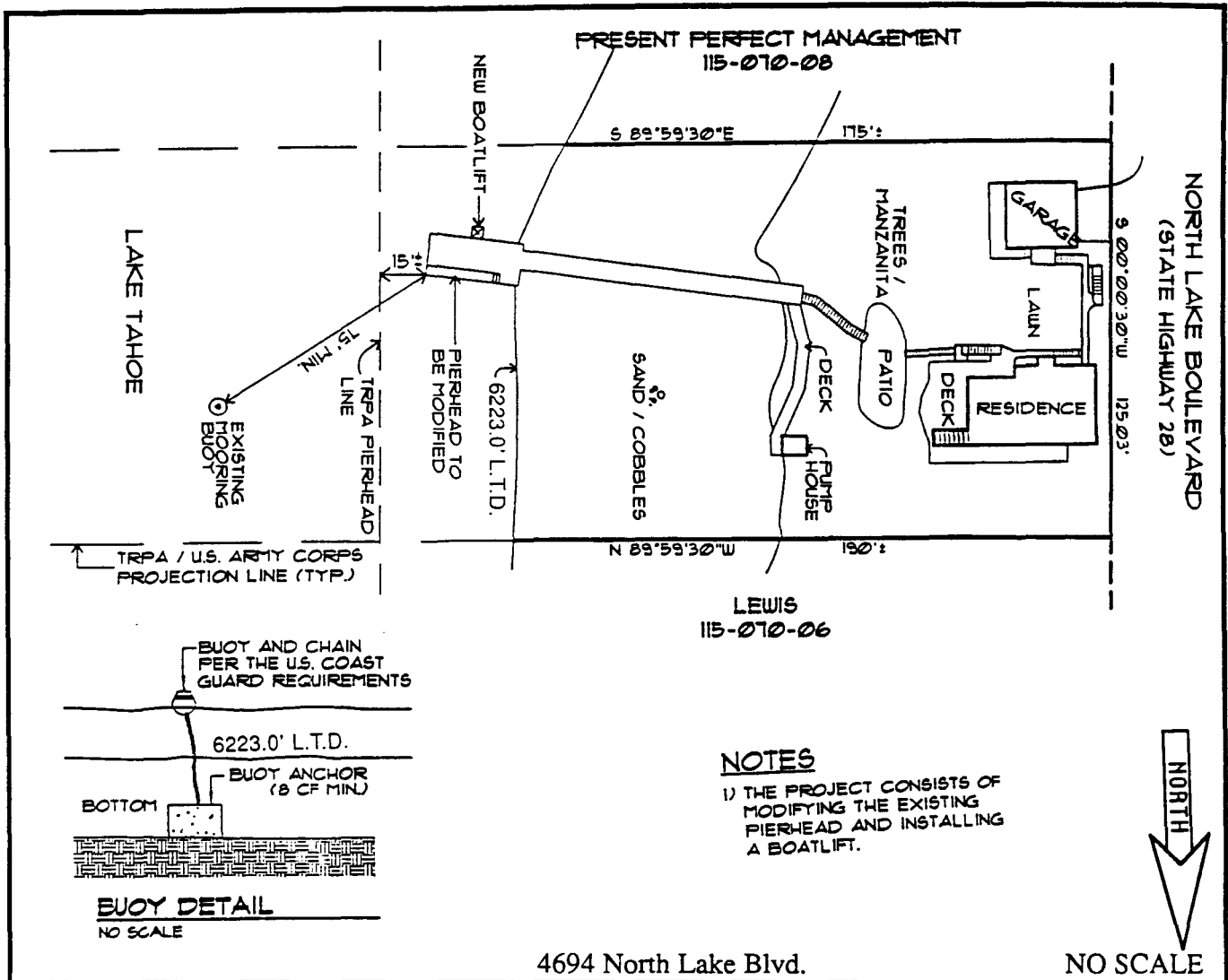

4694 North Lake Blvd.

NO SCALE

LOCATION MAP

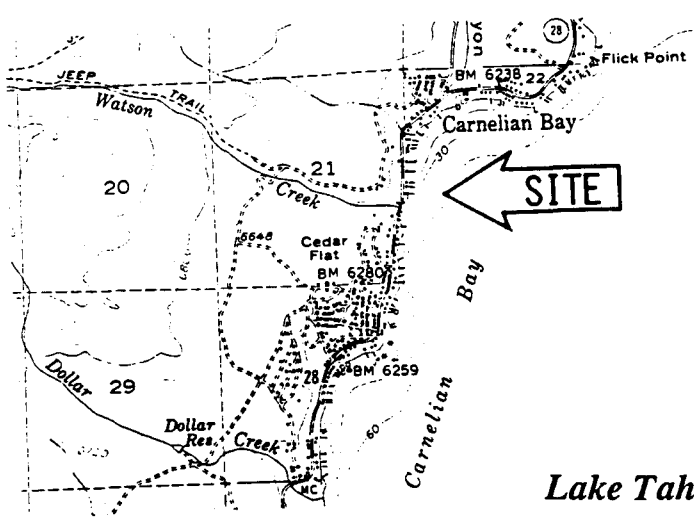

NO SCALE

This Exhibit is solely for purposes of generally defining the lease premises, and is not intended to be, nor shall it be construed as, a waiver or limitation of any State interest in the subject or any other property.

EXHIBIT "A"

PRC 4483.9
APN 115 - 070 - 07
Lake Tahoe
PLACER COUNTY
Sheet 1 of 2 Sheets

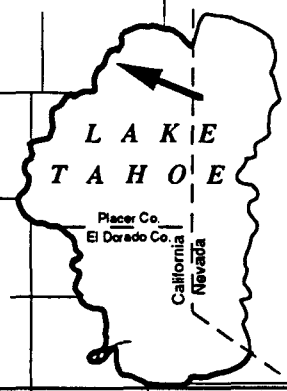

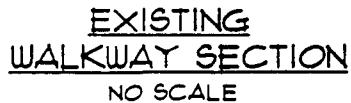
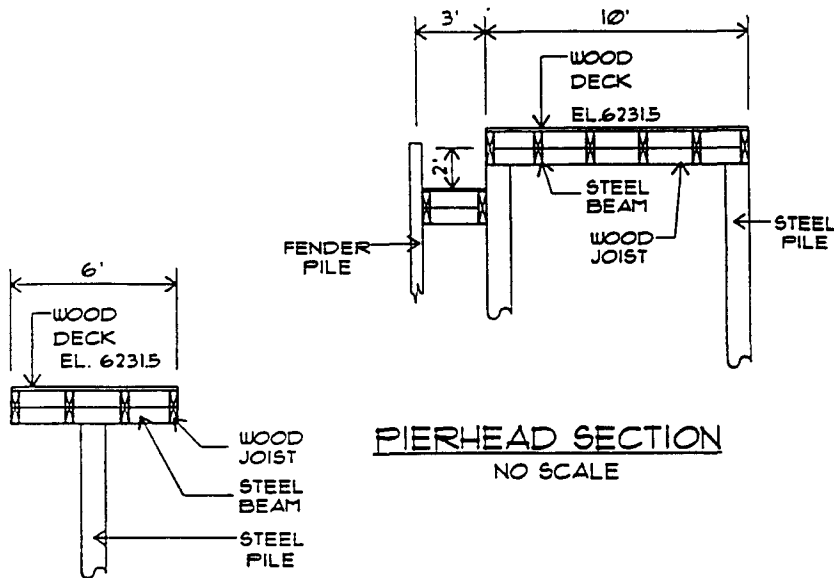
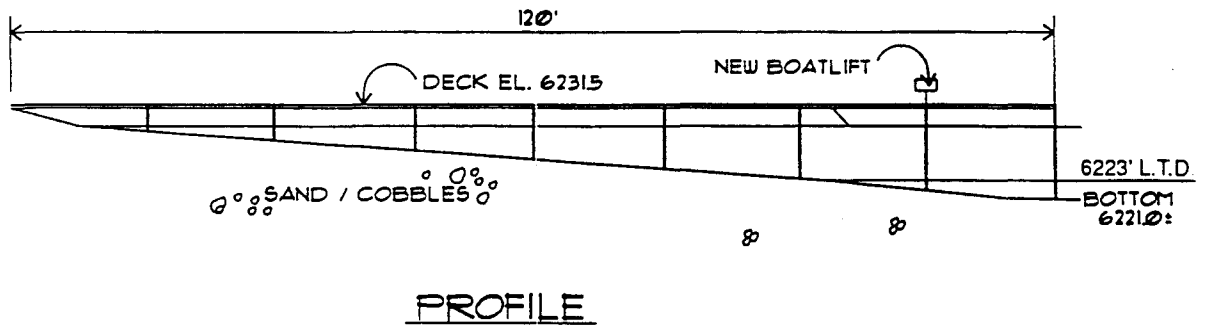
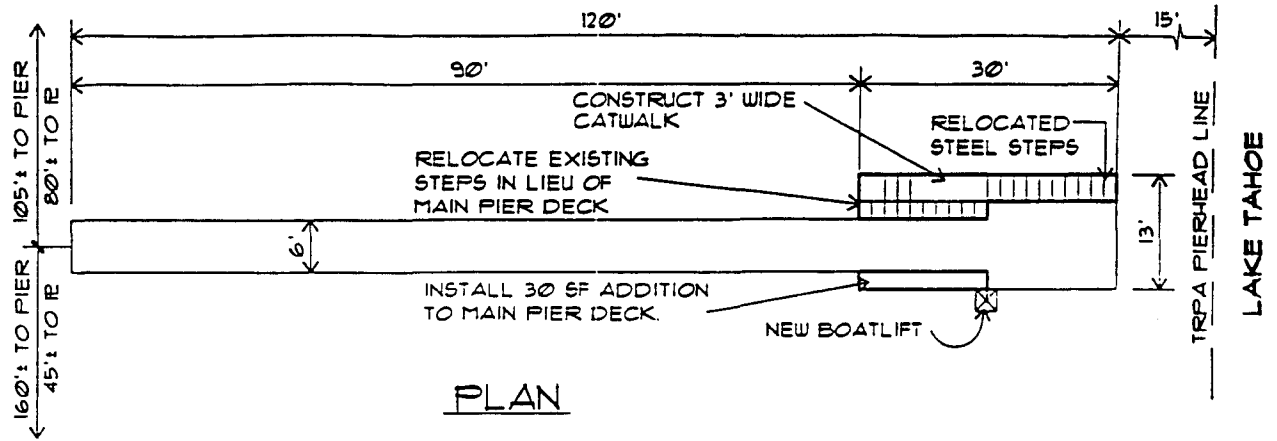

This Exhibit is solely for purposes of generally defining the lease premises, and is not intended to be, nor shall it be construed as, a waiver or limitation of any State interest in the subject or any other property.

NO SCALE

EXHIBIT "A"

PRC 4483.9

APN 115 - 070 - 07

Lake Tahoe

PLACER COUNTY

Sheet 2 of 2 Sheets

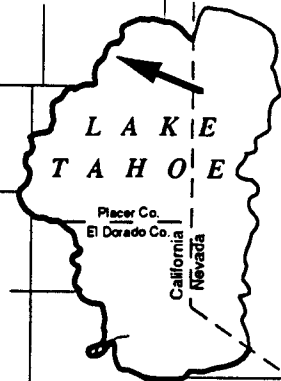

CALENDAR PAGE

200

CG 2/96

MINUTE PAGE

000219