

MINUTE ITEM

This Calendar Item No. ~~014~~ was approved as Minute Item No. 14 by the California State Lands Commission by a vote of 2 to ~~0~~ at its 2/27/96 meeting.

**CALENDAR ITEM
C14**

A 4
S 1

02/27/96
PRC 4311.9
Cooper

RECREATIONAL PIER LEASE

APPLICANT:

Frances B. Nelson, David D. Bohannon, II and Robert Webster, Trustees of the David D. Bohannon and Ophelia E. Bohannon Revocable Living Trusts, dated February 3, 1972

LOCATION:

A parcel of submerged land located in the bed of Lake Tahoe at Tahoe Pines, Placer County.

EXHIBIT:

A. Location Map

AB 884:

N/A

RECOMMENDED ACTION:

IT IS RECOMMENDED THAT THE COMMISSION:

CEQA FINDING:

FIND THAT THE ACTIVITY IS EXEMPT FROM THE REQUIREMENTS OF THE CEQA PURSUANT TO 14 CAL. CODE REGS. 15061 AS A CATEGORICALLY EXEMPT PROJECT, CLASS 1, EXISTING FACILITIES, 2 CAL. CODE REGS. 2905(a)(2).

SIGNIFICANT LANDS

INVENTORY FINDINGS:

FIND THAT THIS ACTIVITY IS CONSISTENT WITH THE USE CLASSIFICATION DESIGNATED FOR THE LAND PURSUANT TO PUBLIC RESOURCES CODE SECTIONS 6370, ET SEQ.

CALENDAR ITEM NO. C14 (CONT'D)

AUTHORIZATION:

AUTHORIZE ISSUANCE TO THE DAVID D. BOHANNON AND OPHYELIA E. BOHANNON REVOCABLE LIVING TRUSTS, DATED FEBRUARY 3, 1972 (FRANCES B. NELSON, DAVID D. BOHANNON, II AND ROBERT WEBSTER, TRUSTEES) OF A TEN-YEAR RECREATIONAL PIER LEASE, BEGINNING AUGUST 10, 1994, ON FILE IN THE COMMISSION'S OFFICES FOR ALL OF THE STATE'S SOVEREIGN LANDS BELOW THE ELEVATION OF 6223 FEET LTD UNDER APPLICANT'S PIER AS DEPICTED ON EXHIBIT "A" ATTACHED AND BY REFERENCE MADE A PART HEREOF; NO MONETARY CONSIDERATION PURSUANT TO PUBLIC RESOURCES CODE SECTION 6503.5.

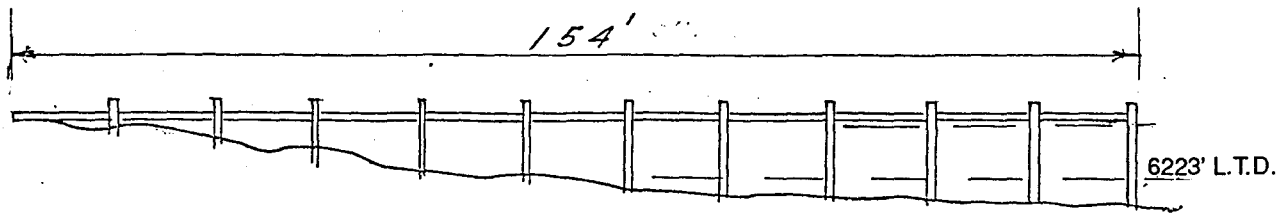

2 4 L B 10
 SCALE in Feet

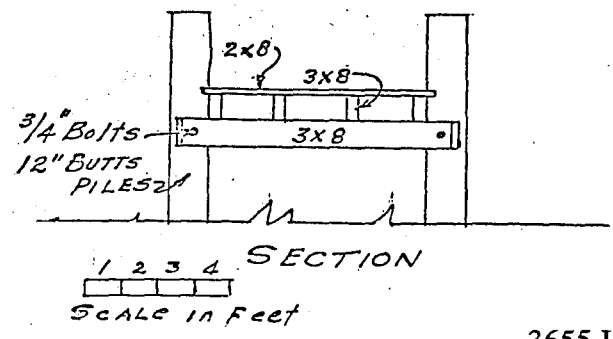
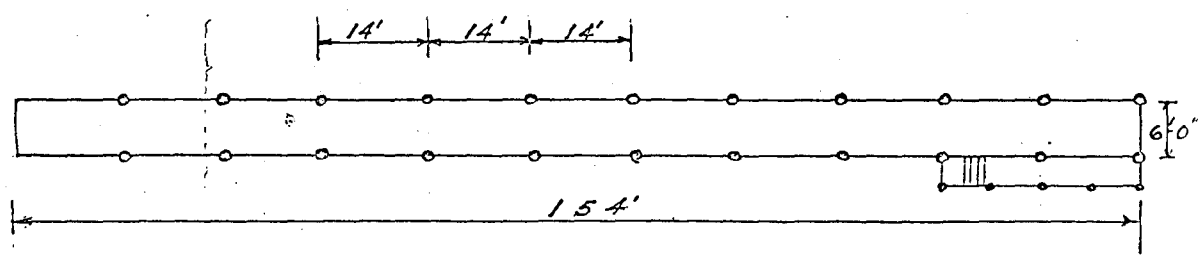

Lake Tahoe

3655 Idlewild Way

LOCATION MAP

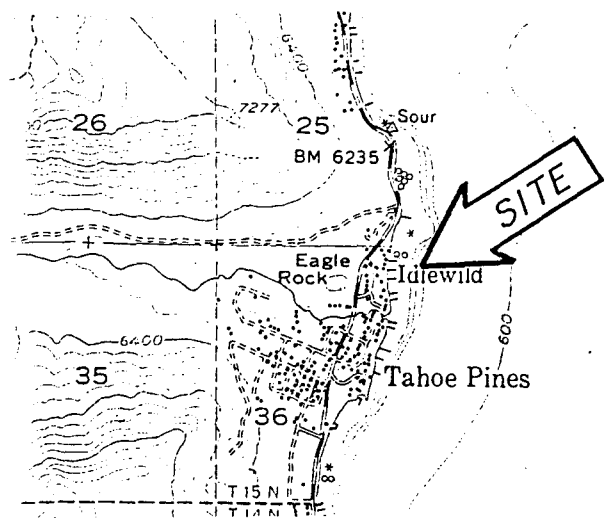

Lake Tahoe

NO SCALE

This Exhibit is solely for purposes of generally defining the lease premises, and is not intended to be, nor shall it be construed as, a waiver or limitation of any State interest in the subject or any other property.

EXHIBIT "A"
 PRC 4311.9
 APN 85 - 190 - 001
 Lake Tahoe
 PLACER COUNTY

