

**MINUTE ITEM**

This Calendar Item No. C08 was approved as Minute Item No. 8 by the California State Lands Commission by a vote of 2 to 0 at its 2/27/96 meeting.

**CALENDAR ITEM  
C08**

A 4

02/27/96

S 1

PRC 5152.1

Cooper

**RECREATIONAL PIER LEASE**

**APPLICANT:**

Kenneth R. and Wauneta M. Arnbrister  
P.O. Box 921  
Tahoe City, California 96145

**LOCATION:**

A parcel of submerged land located in the bed of Lake Tahoe, Carnelian Bay, Placer County.

**EXHIBIT:**

A. Site Map

**AB 884:**

07/22/96

**OTHER PERTINENT INFORMATION:**

This lease is conditioned on the Lessee obtaining authorization from the Tahoe Regional Planning Agency for the existing buoys within two years from the effective date of the authorization of the buoys by the Commission.

**RECOMMENDED**

**ACTION:**

IT IS RECOMMENDED THAT THE COMMISSION:

**CEQA**

**FINDING: (Pier)**

FIND THAT THE ACTIVITY IS EXEMPT FROM THE REQUIREMENTS OF THE CEQA PURSUANT TO 14 CAL. CODE REGS. 15061 AS A CATEGORICALLY EXEMPT PROJECT, CLASS 1, EXISTING FACILITIES (PIER AND BOAT LIFT), 14 CAL. CODE REGS. 15301.

CALENDAR ITEM C08 (CONT'D)

**CEQA FINDING: (Buoys)**

FIND THAT THE ACTIVITY IS EXEMPT FROM THE REQUIREMENTS OF THE CEQA PURSUANT TO 14 CAL. CODE REGS. 15061 AS A CATEGORICALLY EXEMPT PROJECT, CLASS 3, NEW CONSTRUCTION OF SMALL STRUCTURES, 2 CAL. CODE REGS. 2905 (c) (3).

**SIGNIFICANT LANDS**

**INVENTORY FINDING:**

FIND THAT THIS ACTIVITY IS CONSISTENT WITH THE USE CLASSIFICATION DESIGNATED FOR THE LAND PURSUANT TO PUBLIC RESOURCES CODE SECTIONS 6370, ET SEQ.

**AUTHORIZATION:**

AUTHORIZE ISSUANCE TO KENNETH R. AND WAUNETA M. ARNBRISTER OF A TEN-YEAR RECREATIONAL PIER LEASE, BEGINNING JANUARY 30, 1993, ON FILE IN THE COMMISSION'S OFFICES FOR ALL OF THE STATE'S SOVEREIGN LANDS BELOW THE ELEVATION OF 6223 FEET LAKE TAHOE DATUM UNDER APPLICANT'S PIER, BOAT LIFT AND TWO MOORING BUOYS AS DEPICTED ON EXHIBIT "A" ATTACHED AND BY REFERENCE MADE A PART HEREOF; NO MONETARY CONSIDERATION PURSUANT TO PUBLIC RESOURCES CODE SECTION 6503.5.

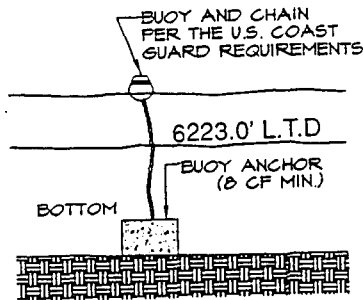
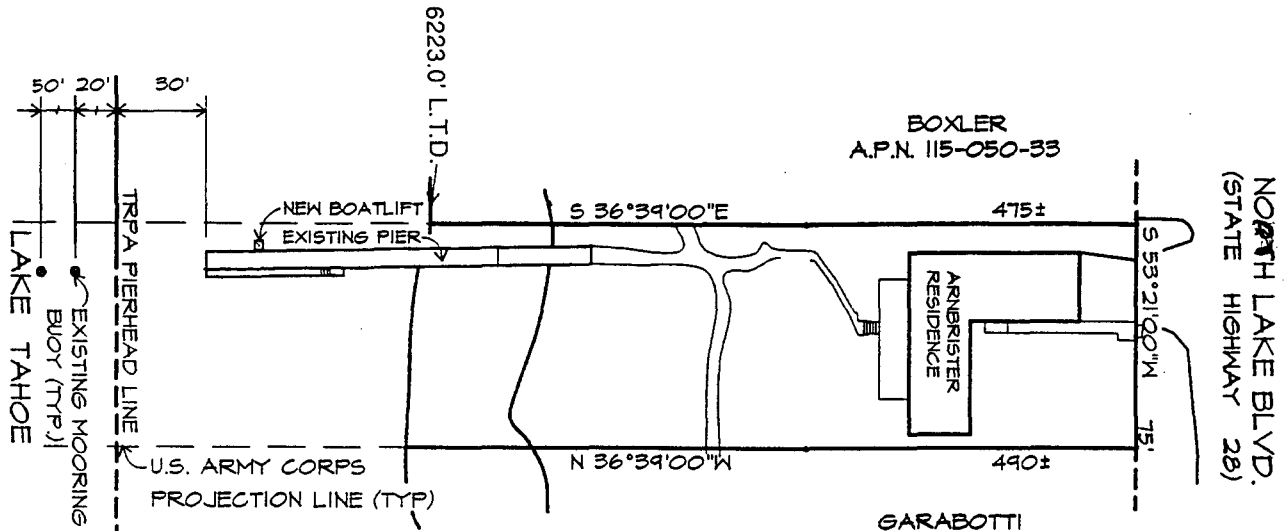

**BUOY DETAIL**  
NO SCALE

4970 N. Lake Blvd.

NO SCALE

**LOCATION MAP**

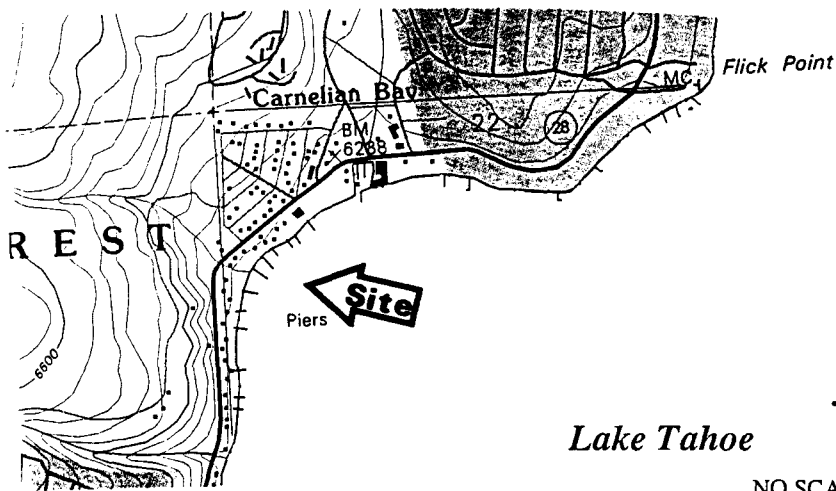

NO SCALE

This Exhibit is solely for purposes of generally defining the lease premises, and is not intended to be, nor shall it be construed as, a waiver or limitation of any State interest in the subject or any other property.

**EXHIBIT "A"**

PRC 5152  
APN 115 - 050 - 032  
Lake Tahoe  
PLACER COUNTY  
Sheet 1 of 2 Sheets

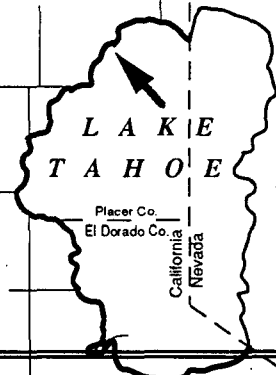

CALENDAR PAGE 25.2

MINUTE PAGE

068099

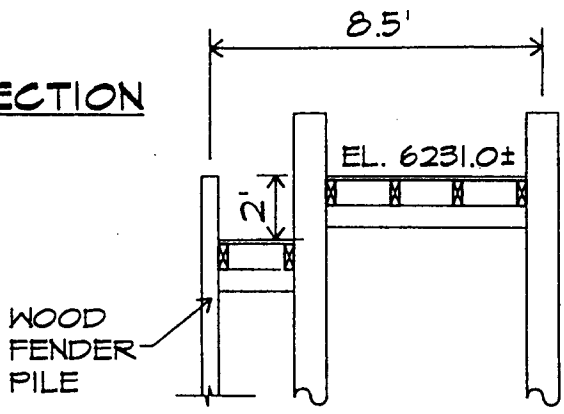
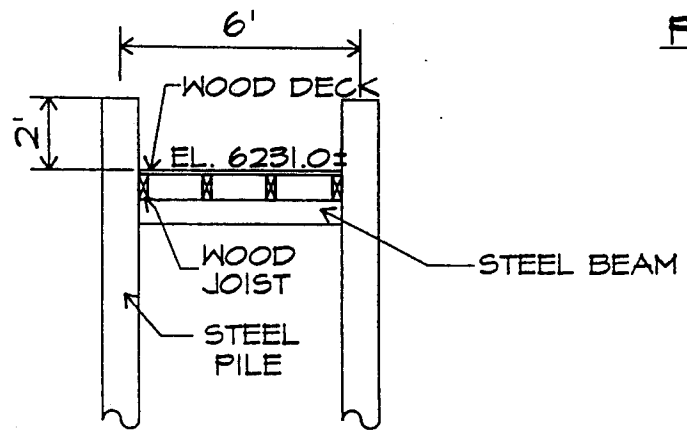
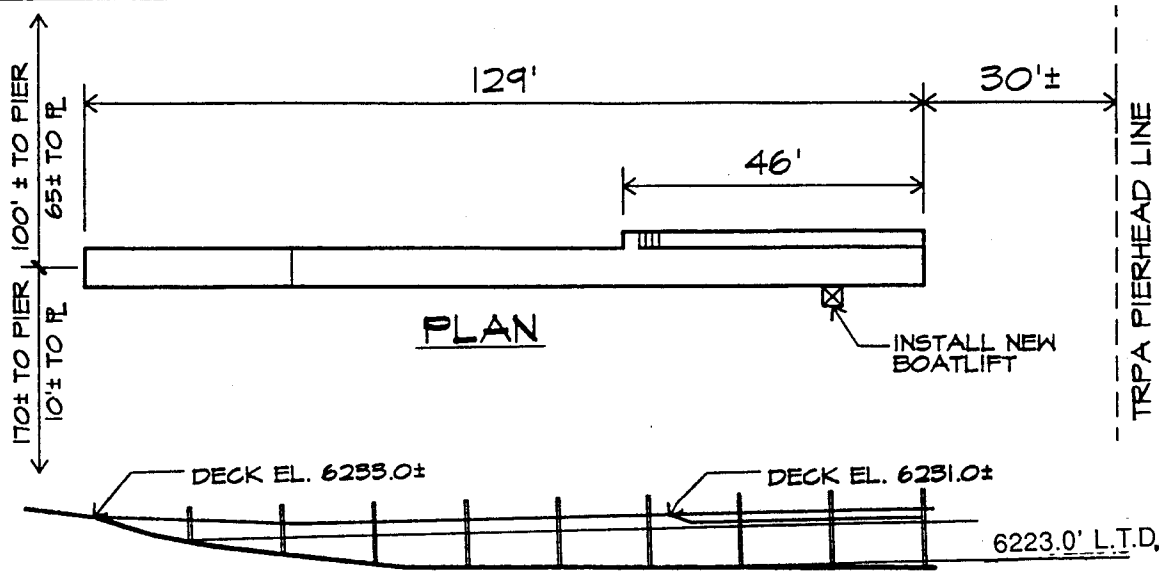

NO SCALE

**EXHIBIT "A"**  
 PRC 5152  
 APN 115 - 050 - 032  
 Lake Tahoe  
 PLACER COUNTY  
 Sheet 2 of 2 Sheets

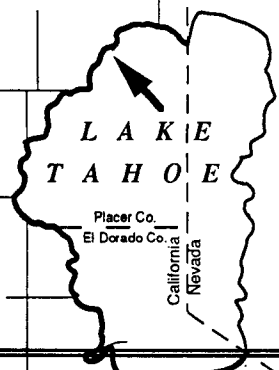

This Exhibit is solely for purposes of generally defining the lease premises, and is not intended to be, nor shall it be construed as, a waiver or limitation of any State interest in the subject or any other property.