

MINUTE ITEM
This Calendar Item No. C15
was approved as Minute Item
No. 15 by the State Lands
Commission by a vote of 3
to 0 at its 9-9-93
meeting.

CALENDAR ITEM

C15

A 4
S 1

09/09/93
W 24749 PRC 7711
J. Ludlow

APPROVE A RECREATIONAL PIER PERMIT

APPLICANT:

Robert J. and Christine L. Feibusch
P.O. Box 6
Ross, California 94957

AREA, TYPE LAND AND LOCATION:

A parcel of submerged land located in Lake Tahoe near
Sunnyside, Placer County.

LAND USE:

Reconstruction of an existing, previously unauthorized, rock
crib pier, including the addition of a low-level boatlift
and retention of one existing, previously unauthorized,
mooring buoy.

TERMS OF PROPOSED LEASE:

Initial period:
Five (5) years beginning September 9, 1993.

CONSIDERATION:

Rent-free pursuant to Section 6503.5 of the P.R.C.

BASIS FOR CONSIDERATION:

Pursuant to 2 Cal. Code Regs. 2003

APPLICANT STATUS:

Applicants are owners of the upland.

PREREQUISITE CONDITIONS, FEES AND EXPENSES:

Filing fee, processing fee, and environmental fee have been
received.

STATUTORY AND OTHER REFERENCES:

- A. P.R.C.: Div. 6, Parts 1 and 2: Div. 13.
- B. Cal Code Regs.: Title 2, Div. 3: Title 14, Div. 6.

(Revised 09/08/93)

-1-

CALENDAR PAGE	79
MINUTE PAGE	1923

CALENDAR ITEM NO. C15 (CONT'D)

AB 884:

09/15/93.

OTHER PERTINENT INFORMATION:

1. Pursuant to the Commission's delegation of authority and the State CEQA Guidelines (14 Cal. Code Regs. 15025), the staff has prepared a Proposed Negative Declaration identified as EIR ND 601, State Clearinghouse No. 92082068. Such Proposed Negative Declaration was prepared and circulated for public review pursuant to the provisions of CEQA.

Based upon the Initial Study, the Proposed Negative Declaration, and the comments received in response thereto, there is no substantial evidence that the project will have a significant effect on the environment. (14 Cal. Code Regs. 15074(b)).

2. A Mitigation Monitoring Plan has been prepared in conformance with the provisions of CEQA (Section 21081.6, P.R.C.) and is attached as Exhibit "D".
3. This activity involves lands identified as possessing significant environmental values pursuant to P.R.C. 6370, et seq. Based upon the staff's consultation with the persons nominating such lands and through the CEQA process, it is the staff's opinion that the project, as proposed, is consistent with its use classification.
4. The applicant proposes to reconstruct an existing, and previously unauthorized, rock crib pier, including the addition of a low-level boatlift and retain one existing, previously unauthorized, mooring buoy. The pier will be reconstructed with an open pile design.
5. The disturbance to the lake bottom will be accomplished using a barge-mounted pile driver which will access the project from the water using floating equipment.
6. No materials will be stored or placed, nor will any activity associated with the construction or maintenance of the project be conducted, above the low water line (elevation 6,223 feet, Lake Tahoe Datum) of the subject property. This procedure will prevent any disturbance to *Rorippa subumbellata*, commonly called

(Revised 09/08/93)

-2-

CALENDAR PAGE	80
MINUTE PAGE	1924

CALENDAR ITEM NO. C15 (CONT'D)

the Tahoe Yellow Cress, a State-listed endangered plant species.

7. The applicant has agreed to incorporate the Interim Management Program Construction and Access Guidelines into the project for the protection of Rorippa and these Guidelines have been included as part of the Negative Declaration referred to herein.
8. The Permit includes specific provisions by which the Permittee agrees to protect and replace or restore, if required, the Rorippa habitat.
9. This permit is issued subject to the applicant providing evidence to the State Lands Commission of authorization of the existing buoy by the Tahoe Regional Planning Agency by September 23, 1994.
10. The subject property was physically inspected by staff for purposes of evaluating the impact of the proposed activity on the public trust.
11. If any structure hereby authorized is found to be in nonconformance with the Tahoe Regional Planning Agency's Shorezone ordinance, and if any alterations, repairs, or removal required pursuant to said ordinance are not accomplished within the designated time period, then this permit is automatically terminated, effective upon notice by the State, and the site shall be cleared pursuant to the terms thereof. If the location, size, or number of any structure hereby authorized is to be altered, pursuant to order of the Tahoe Regional Planning Agency, Permittee shall request the consent of the State to make such alteration.
12. The Permit is conditioned on the public's right of access along the shorezone below the high water line (Elevation 6,228.75 feet, Lake Tahoe Datum), pursuant to the holding in State v. Superior Court (Fogerty), 2 Cal.3d 240 (1981), and provides that the Permittee must provide a reasonable means for public passage along the shorezone, including, but not limited to, the area occupied by the authorized improvements.

CALENDAR ITEM NO. C15 (CONT'D)

13. Permittee agrees to conserve the natural resources on the subject property and to prevent pollution and harm to the environment; and acknowledges that failure to comply with this requirement constitutes a default or breach of the Permit.
14. Staff has determined that the Department of Fish and Game fee, dictated by Section 711.4 of the Fish and Game Code, is applicable to the project as presented herein.

APPROVALS OBTAINED:

Tahoe Regional Planning Agency, Department of Fish and Game, Placer County.

FURTHER APPROVALS REQUIRED:

United States Army Corps of Engineers and State Lands Commission.

EXHIBITS:

- A. Site Map
- B. Location Map
- C. Placer County Letter of Approval
- D. Negative Declaration/Monitoring Program

IT IS RECOMMENDED THAT THE COMMISSION:

1. CERTIFY THAT A NEGATIVE DECLARATION, ND 601 STATE CLEARING HOUSE NO. 92082068, WAS PREPARED FOR THIS PROJECT PURSUANT TO THE PROVISIONS OF THE CEQA AND THAT THE COMMISSION HAS REVIEWED AND CONSIDERED THE INFORMATION CONTAINED THEREIN.
2. ADOPT THE NEGATIVE DECLARATION AND DETERMINE THAT THE PROJECT, AS APPROVED, WILL NOT HAVE A SIGNIFICANT EFFECT ON THE ENVIRONMENT.
3. ADOPT THE MONITORING PROGRAM ATTACHED WITHIN EXHIBIT "D", ATTACHED HERETO.
4. FIND THAT THIS ACTIVITY IS CONSISTENT WITH THE USE CLASSIFICATION DESIGNATED FOR THE LAND PURSUANT TO P.R.C. 6370, ET SEQ.

CALENDAR ITEM NO. C15 (CONT'D)

5. AUTHORIZE ISSUANCE TO ROBERT J. AND CHRISTINE L. FEIBUSCH, OF A FIVE-YEAR RECREATIONAL PIER PERMIT, BEGINNING SEPTEMBER 9, 1993, FOR THE RECONSTRUCTION OF AN EXISTING, PREVIOUSLY UNAUTHORIZED, ROCK CRIB PIER, INCLUDING A BOATLIFT AND RETENTION OF ONE EXISTING, PREVIOUSLY UNAUTHORIZED, MOORING BUOY, ON THE LAND SHOWN ON EXHIBIT "A" ATTACHED, AND BY REFERENCE MADE A PART HEREOF.

(Revised 09/08/93)

-5-

CALENDAR PAGE	83
MINUTE PAGE	1927

Lake

Tahoe

Buoy

Buoy

75°

95°

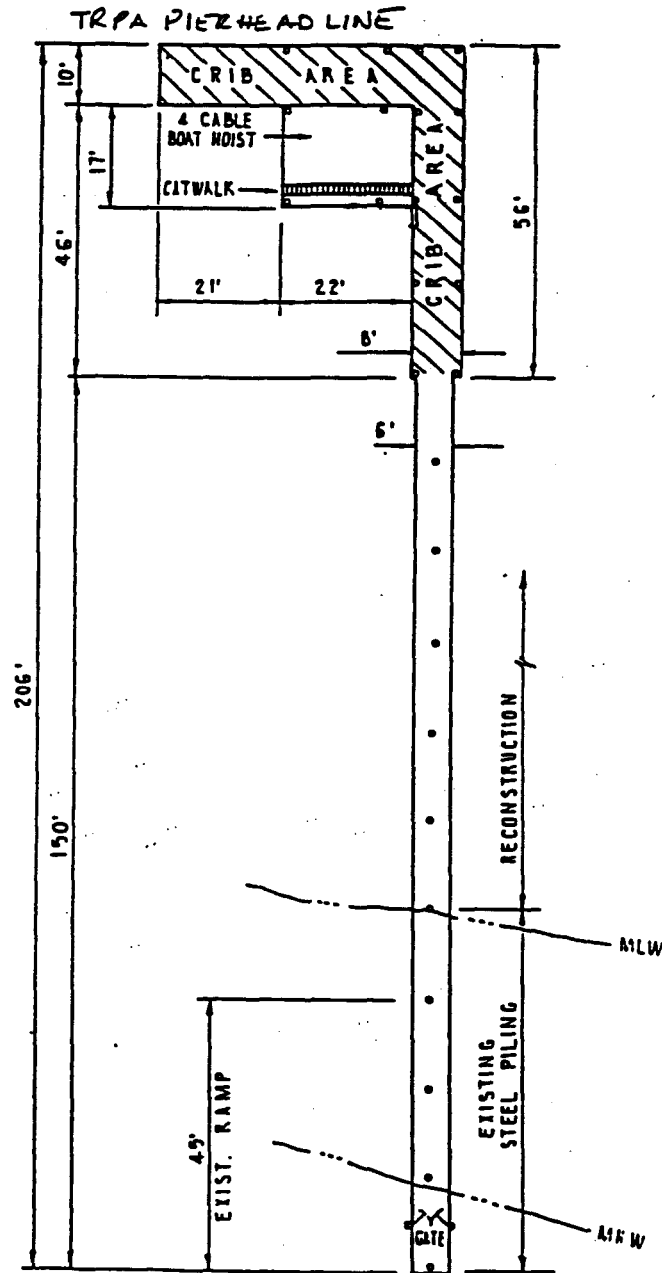

No Scale

EXHIBIT "A"
 Site Map
 W 24749
 APN 83 - 162 - 03
 LAKE TAHOE
 PLACER COUNTY

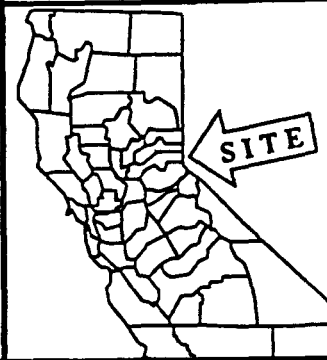

This Exhibit is solely for purposes of generally defining the lease premises, and is not intended to be, nor shall it be construed as, a waiver or limitation of any State interest in the subject or any other property.

CALENDAR PAGE 84
 MINUTE PAGE 1928

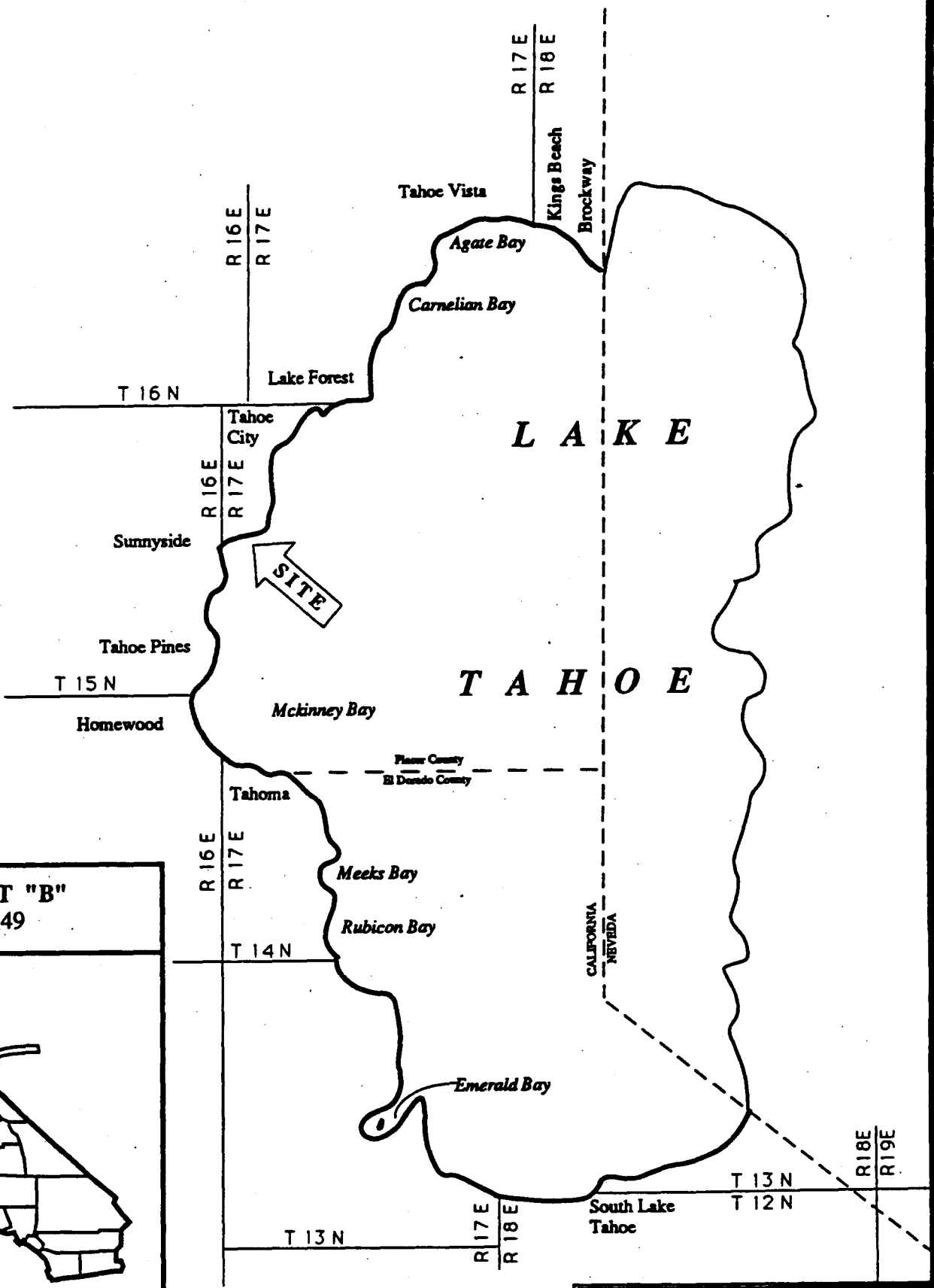

EXHIBIT "B"
W 24749



Date Dec 5, 1991
File Ref: W24749

Ms. Judy Ludlow
California State Lands Commission
1807 13th Street
Sacramento, California 95814

Subject: Building Permit for Pier

Name: Robert Feibusch
Address P.O. Box 6
Ross, Ca 94957

Placer County Assessor's Parcel No. 83-162-03

Upland Address: 1310 West Lake Blvd.

Dear Ms. Ludlow:

The County of Placer has received notice of the above-referenced project in Lake Tahoe and has no objection to the pier repair/ construction or to the issuance of the State Lands Commission's permit.

If you have any questions, you may reach me at (916) 889-7584

Sincerely,



JC JAN CHRISTIAN
Associate Civil Engineer

CALENDAR PAGE	86
MINUTE PAGE	1930

EXHIBIT "D"

STATE LANDS COMMISSION

LEO T. McCARTHY, *Lieutenant Governor*
GRAY DAVIS, *Controller*
THOMAS W. HAYES, *Director of Finance*

EXECUTIVE OFFICE
1807 - 13th Street
Sacramento, CA 95814
CHARLES WARREN
Executive Officer

August 19, 1992
File: W 24749
ND 601

**NOTICE OF PUBLIC REVIEW OF A PROPOSED NEGATIVE DECLARATION
(SECTION 15073 CCR)**

A Negative Declaration has been prepared pursuant to the requirements of the California Environmental Quality Act (Section 21000 et seq., Public Resources Code), the State CEQA guidelines (Section 15000 et seq., Title 14, California Code Regulations), and the State Lands Commission Regulations (Section 2901 et seq., Title 2, California Code Regulations) for a project currently being processed by the staff of the State Lands Commission.

The document is attached for your review. Comments should be addressed to the State Lands Commission office shown above with attention to the undersigned. All comments must be received by September 21, 1992.

Should you have any questions or need additional information, please call the undersigned at (916) 322-7826.

Doug Miller (Handwritten signature with initials "DM" in a circle)

DOUG MILLER
Division of Environmental
Planning and Management

Attachment

CALENDAR PAGE	87
MINUTE PAGE	1931

STATE LANDS COMMISSION

LEO T. McCARTHY, *Lieutenant Governor*
GRAY DAVIS, *Controller*
THOMAS W. HAYES, *Director of Finance*

EXECUTIVE OFFICE
1807 - 13th Street
Sacramento, CA 95814

CHARLES WARR
Executive Officer

PROPOSED NEGATIVE DECLARATION

File: W 24749
ND 601
SCH No. 92082068

Project Title: Feibusch Rock Crib Pier/Boathouse Reconstruction
Proponents: Robert Feibusch
Project Location: Lake Tahoe, 1310 West Lake Blvd., Sunnyside area, APN 83-162-03, Placer County.
Project Description: Authorization to reconstruct and use an existing rock crib pier and boathouse, and retain use of two existing buoys.
Contact Person: Doug Miller Telephone: 916/322-7826

This document is prepared pursuant to the requirements of the California Environmental Quality Act (Section 21000 et seq., Public Resources Code), the State CEQA Guidelines (Section 15000 et seq., Title 14, California Code Regulations), and the State Lands Commission regulations (Section 2901 et seq., Title 2, California Code Regulations).

Based upon the attached Initial Study, it has been found that:

this project will not have a significant effect on the environment.

mitigation measures included in the project will avoid potentially significant effects.

CALENDAR PAGE	88
MINUTE PAGE	1932

ENVIRONMENTAL IMPACT ASSESSMENT CHECKLIST - PART II

Form 13.20 (7/82)

File Ref.: W24749

I. BACKGROUND INFORMATION

A. Applicant: Robert Feibusch Brisco Enterprises-Agent
PO Box 6 PO Box 7468
Ross CA 94957 Tahoe City, CA 96145

B. Checklist Date: 8 / 10 / 92

C. Contact Person: Doug Miller
Telephone: (916) 322-7826

D. Purpose: Propose authorization to reconstruct and use an existing
unauthorized rock-crib pier and boathouse and retain the use of
two existing unauthorized buoys.

E. Location: 1310 West Lake Blvd. (Hwy 89), 1 3/4 miles south of the outlet of
the Truckee River, Sunnyside Area, Lake Tahoe, Placer County
APN 83-162-03.

F. Description: Authorization to reconstruct and use an existing rock-crib pier
and boathouse and retain use of two existing buoys.

G. Persons Contacted:
Jan Brisco - Agent - Brisco Enterprises
Colleen Shade - Tahoe Regional Planning Agency
Ginger Tippet - US Army Corps of Engineers

II. ENVIRONMENTAL IMPACTS. (Explain all "yes" and "maybe" answers)

- A. Earth. Will the proposal result in:
1. Unstable earth conditions or changes in geologic substructures?
2. Disruptions, displacements, compaction, or overcovering of the soil?
3. Change in topography or ground surface relief features?
4. The destruction, covering, or modification of any unique geologic or physical features?
5. Any increase in wind or water erosion of soils, either on or off the site?
6. Changes in deposition or erosion of beach sands, or changes in siltation, deposition or erosion which may modify the channel of a river or stream or the bed of the ocean or any bay, inlet, or lake?
7. Exposure of all people or property to geologic hazards such as earthquakes, landslides, mudslides, ground failure, or similar hazards?

CALENDAR PAGE 89
MINUTE PAGE 1933x

B. *Air*. Will the proposal result in:

- 1. Substantial air emissions or deterioration of ambient air quality?
- 2. The creation of objectionable odors?
- 3. Alteration of air movement, moisture or temperature, or any change in climate, either locally or regionally?

C. *Water*. Will the proposal result in:

- 1. Changes in the currents, or the course or direction of water movements, in either marine or fresh waters?
- 2. Changes in absorption rates, drainage patterns, or the rate and amount of surface water runoff?
- 3. Alterations to the course or flow of flood waters?
- 4. Change in the amount of surface water in any water body?
- 5. Discharge into surface waters, or in any alteration of surface water quality, including but not limited to temperature, dissolved oxygen or turbidity?
- 6. Alteration of the direction or rate of flow of ground waters?
- 7. Change in the quantity of ground waters, either through direct additions or withdrawals, or through interception of an aquifer by cuts or excavations?
- 8. Substantial reduction in the amount of water otherwise available for public water supplies?
- 9. Exposure of people or property to water-related hazards such as flooding or tidal waves?
- 10. Significant changes in the temperature, flow or chemical content of surface thermal springs?

D. *Plant Life*. Will the proposal result in:

- 1. Change in the diversity of species, or number of any species of plants (including trees, shrubs, grass, crops, and aquatic plants)?
- 2. Reduction of the numbers of any unique, rare or endangered species of plants?
- 3. Introduction of new species of plants into an area, or in a barrier to the normal replenishment of existing species?
- 4. Reduction in acreage of any agricultural crop?

E. *Animal Life*. Will the proposal result in:

- 1. Change in the diversity of species, or numbers of any species of animals (birds, land animals including reptiles, fish and shellfish, benthic organisms, or insects)?
- 2. Reduction of the numbers of any unique, rare or endangered species of animals?
- 3. Introduction of new species of animals into an area, or result in a barrier to the migration or movement of animals?
- 4. Deterioration to existing fish or wildlife habitat?

F. *Noise*. Will the proposal result in:

- 1. Increase in existing noise levels?
- 2. Exposure of people to severe noise levels?

G. *Light and Glare*. Will the proposal result in:

- 1. The production of new light or glare?

H. *Land Use*. Will the proposal result in:

- 1. A substantial alteration of the present or planned land use of an area?

I. *Natural Resources*. Will the proposal result in:

- 1. Increase in the rate of use of any natural resources?
- 2. Substantial depletion of any nonrenewable resources?

		Yes	Maybe	No
J. Risk of Upset. Does the proposal result in:				
1.	A risk of an explosion or the release of hazardous substances (including, but not limited to, oil, pesticides, chemicals, or radiation) in the event of an accident or upset conditions?	<input type="checkbox"/>	<input type="checkbox"/>	<input checked="" type="checkbox"/>
2.	Possible interference with emergency response plan or an emergency evacuation plan?	<input type="checkbox"/>	<input type="checkbox"/>	<input checked="" type="checkbox"/>
K. Population. Will the proposal result in:				
1.	The alteration, distribution, density, or growth rate of the human population of the area?	<input type="checkbox"/>	<input type="checkbox"/>	<input checked="" type="checkbox"/>
L. Housing. Will the proposal result in:				
1.	Affecting existing housing, or create a demand for additional housing?	<input type="checkbox"/>	<input type="checkbox"/>	<input checked="" type="checkbox"/>
M. Transportation/Circulation. Will the proposal result in:				
1.	Generation of substantial additional vehicular movement?	<input type="checkbox"/>	<input type="checkbox"/>	<input checked="" type="checkbox"/>
2.	Affecting existing parking facilities, or create a demand for new parking?	<input type="checkbox"/>	<input type="checkbox"/>	<input checked="" type="checkbox"/>
3.	Substantial impact upon existing transportation systems?	<input type="checkbox"/>	<input type="checkbox"/>	<input checked="" type="checkbox"/>
4.	Alterations to present patterns of circulation or movement of people and/or goods?	<input type="checkbox"/>	<input type="checkbox"/>	<input checked="" type="checkbox"/>
5.	Alterations to waterborne, rail, or air traffic?	<input type="checkbox"/>	<input type="checkbox"/>	<input checked="" type="checkbox"/>
6.	Increase in traffic hazards to motor vehicles, bicyclists, or pedestrians?	<input type="checkbox"/>	<input type="checkbox"/>	<input checked="" type="checkbox"/>
N. Public Services. Will the proposal have an effect upon, or result in a need for new or altered governmental services in any of the following areas:				
1.	Fire protection?	<input type="checkbox"/>	<input type="checkbox"/>	<input checked="" type="checkbox"/>
2.	Police protection?	<input type="checkbox"/>	<input type="checkbox"/>	<input checked="" type="checkbox"/>
3.	Schools?	<input type="checkbox"/>	<input type="checkbox"/>	<input checked="" type="checkbox"/>
4.	Parks and other recreational facilities?	<input type="checkbox"/>	<input type="checkbox"/>	<input checked="" type="checkbox"/>
5.	Maintenance of public facilities, including roads?	<input type="checkbox"/>	<input type="checkbox"/>	<input checked="" type="checkbox"/>
6.	Other governmental services?	<input type="checkbox"/>	<input type="checkbox"/>	<input checked="" type="checkbox"/>
O. Energy. Will the proposal result in:				
1.	Use of substantial amounts of fuel or energy?	<input type="checkbox"/>	<input type="checkbox"/>	<input checked="" type="checkbox"/>
2.	Substantial increase in demand upon existing sources of energy, or require the development of new sources?	<input type="checkbox"/>	<input type="checkbox"/>	<input checked="" type="checkbox"/>
P. Utilities. Will the proposal result in a need for new systems, or substantial alterations to the following utilities:				
1.	Power or natural gas?	<input type="checkbox"/>	<input type="checkbox"/>	<input checked="" type="checkbox"/>
2.	Communication systems?	<input type="checkbox"/>	<input type="checkbox"/>	<input checked="" type="checkbox"/>
3.	Water?	<input type="checkbox"/>	<input type="checkbox"/>	<input checked="" type="checkbox"/>
4.	Sewer or septic tanks?	<input type="checkbox"/>	<input type="checkbox"/>	<input checked="" type="checkbox"/>
5.	Storm water drainage?	<input type="checkbox"/>	<input type="checkbox"/>	<input checked="" type="checkbox"/>
6.	Solid waste and disposal?	<input type="checkbox"/>	<input type="checkbox"/>	<input checked="" type="checkbox"/>
Q. Human Health. Will the proposal result in:				
1.	Creation of any health hazard or potential health hazard (excluding mental health)?	<input type="checkbox"/>	<input type="checkbox"/>	<input checked="" type="checkbox"/>
2.	Exposure of people to potential health hazards?	<input type="checkbox"/>	<input type="checkbox"/>	<input checked="" type="checkbox"/>
R. Aesthetics. Will the proposal result in:				
1.	The obstruction of any scenic vista or view open to the public, or will the proposal result in the creation of an aesthetically offensive site open to public view?	<input type="checkbox"/>	<input type="checkbox"/>	<input checked="" type="checkbox"/>
S. Recreation. Will the proposal result in:				
1.	An impact upon the quality or quantity of existing recreational opportunities?	<input type="checkbox"/>	<input type="checkbox"/>	<input checked="" type="checkbox"/>

Yes Maybe No

T. Cultural Resources

- 1. Will the proposal result in the alteration of or the destruction of a prehistoric or historic archeological site?
- 2. Will the proposal result in adverse physical or aesthetic effects to a prehistoric or historic building, structure, or object?
- 3. Does the proposal have the potential to cause a physical change which would affect unique ethnic cultural values?
- 4. Will the proposal restrict existing religious or sacred uses within the potential impact area?

U. Mandatory Findings of Significance

- 1. Does the project have the potential to degrade the quality of the environment, reduce the habitat of a fish or wildlife species, cause a fish or wildlife population to drop below self-sustaining levels, threaten to eliminate a plant or animal community, reduce the number or restrict the range of a rare or endangered plant or animal or eliminate important examples of the major periods of California history or prehistory?
- 2. Does the project have the potential to achieve short-term, to the disadvantage of long-term, environmental goals?
- 3. Does the project have impacts which are individually limited, but cumulatively considerable?
- 4. Does the project have environmental effects which will cause substantial adverse effects on human beings, either directly or indirectly?

III. DISCUSSION OF ENVIRONMENTAL EVALUATION (See Comments Attached)

SEE ATTACHED

IV. PRELIMINARY DETERMINATION

On the basis of this initial evaluation:

- I find the proposed project COULD NOT have a significant effect on the environment, and a NEGATIVE DECLARATION will be prepared.
- I find that although the proposed project could have a significant effect on the environment, there will not be a significant effect in this case because the mitigation measures described on an attached sheet have been added to the project. A NEGATIVE DECLARATION will be prepared.
- I find the proposed project MAY have a significant effect on the environment, and an ENVIRONMENTAL IMPACT REPORT is required.

Date: 8 / 10 / 92

CALENDAR PAGE	92
<i>Donna Miller</i>	1936

For the State Lands Commission

(4)

PROJECT DESCRIPTIONPROJECT NARRATIVE

W 24749 proposes authorization for the use of two existing unauthorized mooring buoys and use and reconstruction/repair of the existing unauthorized recreational pier, boatlift, and boathouse. The proposed project involves the authorization for the reconstruction of the existing open piling and rock crib pier and boathouse. Reconstruction shall begin lakeward from elevation 6223 feet and shall be accomplished using a barge or "Lark" type vehicle equipped with a pile driver. The four cable boat hoist will be an integral part of the boathouse.

The repairs will consist of removal and replacement of all rotten wood pilings, stringers, cribbing, and decking for the pier and boathouse. The existing boat hoist in the boat house will be replaced with a new four cable boat hoist mounted in the boat house. The boathouse resembles a raised sundeck supported by four pilings without walls. The rock crib pierhead is "L" shaped and forms two low lakeward protective walls for the "boathouse".

The reconstruction will use steel pilings, steel H beams, wood stringers and wood decking. The repair will be accomplished through use of a "Lark" vessel, a boat/floating barge with over inflated tires. Access to the site will be completely from the water for both materials and equipment.

The first stage of the construction will be to remove the old structure. Access will be from the lark vessel and the existing structure. Disturbance will be restricted to the footprint of the existing structure plus a ten foot construction zone running the complete pier length on one side of the pier. The ten foot construction zone location will be determined at the TRPA preconstruction meeting.

The pier will be dismantled from the beach end to the lake end. The pilings will be removed by a clam-shell type attachment to the pile driver on the lark vessel.

The second phase will consist of driving the new steel piles six feet deep into the lakebed substrate in a single (centered) piling style spaced 15 ft. apart, for the first 90 ft., and then changing to a double piling configuration for the "L" shaped rock crib portion of the rest of the length of the pierhead and boathouse. The rotten wood forming the cribbing will be replaced and the same rock will be used to refill the cribbing which forms a breakwater for the boat house. The rock cribbing will occupy its footprint. The new pilings will be driven whenever possible.

piling holes of the previous structure. If this is not possible, the new pilings will be driven as close to the old hole as structurally possible.

All the pilings to be replaced are located below 6223 ft. and will be driven by the pile driver mounted on the "Lark" vessel while it is in the lake. Pilings located above the lake level, but below 6223 ft. (the current lake level is below 6223 ft.) will be accessed from the "Lark" while within the 10 ft. construction zone. Next the "H" beams will be welded to the pilings, the stringers mounted on the "H" beams, the decking installed, and the boatlift constructed. This will all be accomplished within the existing footprint of the pier and boathouse, plus the 10 ft. construction zone on one side of the pier up to 6223 feet. The materials generated by the demolition and materials for the reconstruction will be stored on the "Lark" vessel, barge, or dumpster for later disposal at an approved landfill.

CONSTRUCTION METHOD

This project consists of the removal of the existing rotten wooden pilings and replacing them with 10-3/4" diameter steel piling, "H" beam caps, wood stringers, and wood decking. The boat lift will be an integral part of the boathouse. Best practical control technology shall be employed to prevent earthen materials to be resuspended as a result of pier construction and from being transported to adjacent lake waters. The applicant shall install a turbidity screen around the entire construction site (in the water), or use caissons or vertical cylinders (sleeves) to prevent the release of resuspended sediments during pile placement activities from entering the lake. Small boats and/or tarps will be placed under the reconstruction area as necessary to collect construction debris. If disturbed lakebottom sediments are found due to the construction activity associated with the installation of this project, the affected areas will be hand rolled and/or rock cobble to be hand picked to reconsolidate the lakebottom sediments. There will be no storage of materials above the low water line of the subject property.

CALENDAR PAGE	94
MINUTE PAGE	1938

DESCRIPTION OF ENVIRONMENTAL SETTING

W 24749

The proposed reconstruction project is located at 1310 West Lake Blvd., Placer County, California. This is a private residence in the Sunnyside area, approximately 1 3/4 miles south of the outlet of the Truckee River in Tahoe City on Highway 89 (West Lake Blvd.) APN 83-162-03. The present use of the area is private recreation. Two buoys, a pier and boathouse presently exist on the project site. The Sunnyside shoreline is primarily rocky, generally offering little habitat for Tahoe Yellow Cress (TYC), Rorippa subumbellata.

SITE DESCRIPTION

The Feibusch property and the two adjacent lots presently have piers. There is a back beach bank, and the homes sit above the lake level on a bluff. Beach access is very difficult without the use of the pier due to the steep back bank. The use of the piers does not require any foot traffic on the littoral zone between the elevation of 6232 ft. and 6221 ft. The TYC survey area includes the neighboring parcel to the north. The lake level was recorded at 6221.7 ft. at Tahoe City on April 18, 1992, the date of the survey.

SUBSTRATE AND TOPOGRAPHY

The substrate is very uniform throughout the site. It consists of unsorted rocks ranging in size from 1 to 12 inches in diameter over a silt/clay mixture. The substrate of silt and clay is very unusual for the lake shore and is found both at the surface in areas of few rocks and at depth under the piled rocks. The silt/clay mixture was found throughout the site with one exception where a small band of sand exists at the edge of the survey area, which is 18 ft. long by 8 ft. wide of coarse sand (1/2 to 1.0 mm) with scattered boulders.

The topography of the beach is a gentle steady upslope from 6221 ft. up to a back beach bank at 6230 ft. At the maximum lake elevation, the beach has a width of 100 ft. No back beach depressions or wave berms are present. High and low water levels are indicated in relation to the pier on the attached map (Exhibit "A") along with the topographic profile of the site.

VEGETATION

Plants are present throughout the site, the greatest concentration being in the back beach area. Willow, clover, and willow herb are the most common, being scattered across the beach; other species are found occasionally. The sand pocket at the south end of the study site supports the only mullein present on the site. The soil is moist directly underneath the rocks and at

CALENDAR PAGE	95
MINUTE PAGE	1939

CONCLUSIONS

TYC was not found within the survey area nor has it ever been documented to occur at this site. The rocky shoreline of the Sunnyside area and the lack of beach at maximum lake level greatly limits the potential for TYC habitat. The distance from Ward Creek without any habitat between the two sites also limits colonization potential. Besides willows, the typical plant species with which TYC is associated are not present at this site.

The clay/silt substrate indicates that this area would not be potential habitat for TYC. The pocket of sand at the south end is very small and isolated, reducing the probability of viable habitat for TYC.

The shorezone in the area of the proposed project is mapped as significant spawning and feeding and escape habitat on the Prime Fish Habitat Maps identified by the Tahoe Regional Planning Agency. Construction will be limited to the non fish spawning season between July 1 and October 1. There are existing piers located approximately 170 feet northeast and 30 feet southwest from the Feibusch's property lines.

CALENDAR PAGE	96
MINUTE PAGE	1940

DISCUSSION OF ENVIRONMENTAL EVALUATION
FEIBUSCH'S TWO RECREATIONAL BUOYS AND
PIER, BOATHOUSE, AND BOATLIFT RECONSTRUCTION PROJECT

W 24749

A. Earth

1. Earth Conditions

No. The pier and boathouse reconstruction project consists primarily of driving pilings about six feet into the lakebed substrate confined to the surface and will not create any unstable conditions or change any geological structure. The two existing buoys will not create any new effects on earth conditions.

2. Compaction, Overcovering of Soil

No. The pier and boathouse reconstruction operation will be essentially confined to the footprint of the existing pier. See exhibit A. There will be no new overcovering of lake bottom substrate or upland soils during the pier and boathouse reconstruction because of the open pile design of the pier. The rockcrib portion of the pier will use the same rock put back into the crib as was there before; therefore, there will not be any new areas overcovered. All excess rock will be stored on the barge until it is ready to be placed back in the crib. The two existing buoys will not create any new effects on compaction or overcovering of lakebottom substrate.

3. Topography

No. This open piling pier and boathouse reconstruction project and two existing buoys will not create any new changes in ground surface relief. There will not be any excavating. This project will not create any new significant impacts to ground surface relief.

4. Unique Features

No. The geology in the project area consists of glacial and alluvial deposits. The lake bed at the site is essentially flat and lacks unique features. The continued existence of the two buoys and the removal and driving of replacement piles for the pier and boathouse and the repair of the cribbing portion of the pier will not change any geological or physical features.

5. Erosion

CALENDAR PAGE	97
MINUTE PAGE	1941

No. The proposed authorization to use the existing two buoys and to reconstruct the existing pier and boathouse is simply using and repairing existing structures and will effect no changes on wind or water erosion on or off the site.

6. Siltation

No. This proposed project authorizes the use of two existing buoys and the reconstruction of an existing pier and boathouse which will not create any channel changes, erosion, or siltation.

7. Geologic Hazards

No. The use of the two existing buoys and the reconstruction of the existing pier and boathouse are of a surface nature and will not create forces deep enough to induce any seismic instabilities or ground failures. The pilings being driven in to support the pier and boathouse will not create any new significant geological impacts or hazards.

B. Air

1. Emmissions

No. The two existing buoys and reconstructed pier and boathouse will not affect the air quality. However, during construction hours, there will be about a four week period when fumes from the diesel engine will be emmitted in the immediate vicinity of the project. These emmissions will be immediately dispersed by the prevailing winds. Upon completion this proposed pier reconstruction project will not create any new significant emmissions.

2. Odors

No. The two existing buoys and reconstructed pier and boathouse will not create objectionable odors. However, during construction hours, there will be about a four week period when fumes from the diesel engine will be noticeable in the immediate vicinity of the project. These emmissions will be immediately dispersed by the prevailing winds. Upon completion this proposed pier reconstruction project will not create any new significant emmissions.

3. Climate

No. The two buoys and the reconstructed pier and boathouse will not create any major changes in air movements, temperature, or climate, nor create any

abnormal weather conditions.

C. Water

1. Currents

No. The two buoys and reconstructed pier and boathouse in their footprints are of a static nature and will not create any changes in water currents or movements.

2. Runoff

No. The existing buoys, reconstructed pier and boathouse in their own footprint will not affect absorption rates, drainage patterns, etc. The area adjacent to the existing pier, boathouse and bouys is submerged.

3. Flood Waters

No. The two existing buoys, reconstructed existing pier and boathouse will not create any new effects upon flood waters.

4. Surface Water

No. The two existing buoys, reconstructed existing pier and boathouse are static in nature and will not affect the area of surface water at Lake Tahoe.

5. Turbidity

No. Mitigation measures required by the Tahoe Regional Planning Agency (TRPA) include the applicant installing a turbidity screen around the entire construction site (in the water), or using caissons or vertical cylinders (sleeves) to prevent the release of resuspended sediments during pile (includes H beams) placement activities from entering the lake. Small boats and/or tarps will be placed under the reconstruction area as necessary to collect construction debris. The reconstructed pier and boathouse will not change the water quality.

6. Ground Water Flows

No. The geology of the project area is composed of glacial and alluvial deposits. This entire project takes place below 6223 which is the mean low water level of the lake. The reconstruction of the existing pier and boathouse, and the two existing buoys are all relatively shallow operations and should not affect ground water flows.

7. Ground Water Quantity

No. This project will not alter any aquifers nor consume any ground water. There will not be any changes to ground water quantity caused by the two existing buoys and the reconstructed pier and boathouse.

8. Water Supplies

No. This is not a water consuming project. The existing two buoys and reconstructed pier and boathouse will have no effect on public water supplies.

9. Flooding

No. The two existing buoys and reconstructed existing pier and boathouse will not expose people or property to water-related hazards such as tidal waves or induce flooding.

10. Thermal Springs

No. There are no thermal springs in the vicinity which could be affected by this project.

D. Plant Life

1. Species Diversity

No. There will be a temporary change in aquatic sessile plants during the reconstruction period which will be approximately four weeks. This temporary change will only affect the construction area which will be isolated by a turbidity screen, caisson, etc. This will not constitute a permanent or significant change. The indigenous aquatic sessile flora will shortly begin recolonizing the affected area after the project has been completed. The impact to aquatic plants will be temporary. No new areas will be encumbered.

2. Endangered Species

No. There are no rare or endangered species on the property. In the report for Tahoe Yellow Cress (Rorippa subumbellata) habitat, no TYC was found on the project property or adjacent properties.

3. Introduction of Plants

No. The continued use of the two existing buoys and the pier and boathouse reconstruction project will not introduce any new species to the area nor exclude existing species from becoming established.

CALENDAR PAGE 100

MINUTE PAGE 1944

4. Agriculture Crops

No. The continued use of the two existing buoys and the reconstruction project will not reduce the acreage of agricultural crops. There are no known agriculture or aquaculture activities in this area; therefore, there will be no impacts.

E. Animal Life

1. Species Diversity

No. There will be a temporary disruption in aquatic animal life confined to the actual reconstruction area by the turbidity screens. The construction period will be approximately four weeks. Upon completion of the project, the indigenous aquatic fauna will begin to re-occupy any voids created during the repair operation. The reconstruction project will be conducted during the non-spawning season, identified to be between July 1, 1992 and October 1, 1992 to minimize the impact on fish spawning habitat.

2. Endangered Species

No. There have not been any rare or endangered aquatic animals reported within the project area. No impacts are anticipated.

3. Introduction of Plants

No. The pier reconstruction and boat lift project will not introduce any new species to the area nor create a new barrier to aquatic animals.

4. Habitat Deterioration

No. The reconstruction project will not reduce the aquatic animal habitat area upon completion.

F. Noise

1. Increases

No. The two buoys reconstructed private recreational pier and boathouse will not increase existing noise levels. There will be short term additional noises during the reconstruction period, but there will not be an increase in long term noise levels.

2. Severe Noise

No. The two existing buoys and the reconstructed pier

and boathouse will not create any new severe noise levels; however, there will be a temporary period when the noise levels increase during the period of reconstruction. Upon completion of the project, the noise levels will return to normal. The construction personnel will be subjected to higher noise levels, but they wear hearing protective devices. The general public will not be exposed to this increased noise level because the private property between the project and Highway 89 will act as a buffer.

G. Light and Glare

1. No. The continued use of the two existing buoys and the reconstructed pier and boathouse will not result in creating any new significant light or glare.

H. Land Use

1. No. The continued use of the the two existing buoys and the repair/reconstruction of the existing private recreational pier and boathouse will not alter the present or planned use of the area. The existing pier serves a private residence and not the general public. There are presently buoys, piers, and boathouses on adjacent properties. This project will not create any changes or effects which could substantially alter the land use in the area.

I. Natural Resources

1. Increase in Use

No. The continued seasonal recreational use of the two existing buoys, the reconstructed private pier and boathouse by the Feibusch family will not create any new effects upon the use rate of the natural resource.

2. Depletion of any Nonrenewable Resources

No. The Feibusch family's seasonal use of their private recreational buoys, pier, and boathouse will not create any changes which could deplete any nonrenewable resource.

J. Risk of Upset

1. Risk of Explosion

No. The project involves the dismantling and

reconstruction of an existing pier and boathouse. The "Lark" vessel being used is diesel operated which reduces the risk of explosion. Hazardous materials are not to be used during the reconstruction phase, but mitigation measures have been planned in the event that there is an accidental spill during construction.

Small boats and/or tarps will be placed under the reconstruction area as necessary to collect construction debris. The use of a turbidity screen surrounding the construction area or caissons or vertical cylinders (sleeves) will be required to prevent the release of resuspended sediments during the pile placement activities from entering the lake during reconstruction.

The past limited seasonal use of this and adjacent private family recreational piers have not demonstrated a risk of releasing hazardous substances, creating upset conditions, or explosions in the Lake Tahoe Basin. Precautions will be taken to minimize these risks.

2. Emergency Plan Response

No. The seasonal use of the Feibusch's existing private recreational pier, boathouse, and buoys will not create an interface with any emergency response or any evacuation plan.

K. Population

1. No. The seasonal recreational use of the Feibusch family's existing buoys and reconstructed pier and boathouse will not alter the population in the lake basin.

L. Housing

1. No. The continued seasonal use of the Feibusch family's two existing buoys and reconstructed pier and boathouse will not create a demand for additional housing in the lake basin.

M. Transportation/Circulation

1. Vehicular Movement

No. This is a private residence and the two existing buoys and the reconstructed pier and boathouse are for the use and benefit of the members of the Feibusch family and not the general public. There are no facilities being added to attract more people. The use of this private residence will not be changed by this project nor

will there be any substantial increase in vehicle movement created by this project.

2. Parking

No. See #1 above.

3. Transportation System

No. See #1 above.

4. Circulation

No. See #1 above.

5. Traffic

No. See #1 above.

6. Traffic Hazards

No. See #1 above.

N. Public Services

1. Fire Protection

No. This is a private residence and the two existing buoys and reconstructed pier and boathouse will not create any additional use or increase of use by the general public. This project will not create any new demands on government agencies and services such as fire, police protection, parks and recreation, road maintenance, etc.

2. Police Protection

No. See #1 above.

3. Schools

No. See #1 above.

4. Parks and Recreation Facilities

No. See #1 above.

5. Maintenance of Public Facilities

No. See #1 above.

6. Government services

No. See #1 above.

O. Energy

1. Fuel and Energy

1

No. This is a private residence and the two existing buoys and reconstructed pier and boathouse will not create any additional use or increase of use by the general public. The boat lift is only used when lowering or raising the boat. This pier repair project will not have any significant effect on additional energy consumption. This use will not constitute a substantial increase in energy being used in the Lake Tahoe Basin.

2. Existing Energy Sources

No. See #1 above.

P. Utilities

1. Power or Natural Gas

No. This is a private residence and the two existing buoys and reconstructed pier and boathouse will not create any additional use or increase of use by the general public. The reconstruction of the private recreational pier will not create any changes in utilities. This project is for the private benefit of the Feibusch family. There will be no additions to the existing facilities which will significantly affect the current uses of power, communications, water, septic tanks, storm water drainage, or solid waste disposal.

2. Communication Systems

No. See #1 above.

3. Water

No. See #1 above.

4. Sewer or Septic Tanks

No. See #1 above.

5. Storm Water Drainage

No. See #1 above.

6. Solid Waste Disposal

No. See #1 above.

Q. Human Health

1. Health Hazard

No. To the contrary, the repaired private recreational pier and boathouse will eliminate a safety hazard and will not create any health hazards to humans.

2. Exposure of People to Health Hazards

No. The two buoys and the repaired private recreational pier and boathouse will not expose people to any new potential health hazards.

R. Aesthetics

- 1. No.** This is a residential recreational area consisting of homes, piers, boathouses, buoys, sun decks, and boats. The reconstruction of the pier and boathouse will not be a distraction, but compliment the aesthetics of this residential recreational area.

S. Recreation

- 1. No.** The two existing buoys and the reconstruction of this private recreational pier and boathouse will have no effect on public recreation in the area.

T. Cultural Resources

1. Archaeological Sites

No. The use of the two existing buoys and the reconstructed private recreational pier and boathouse within their existing footprint will not create any new significant impacts. There are no identified cultural, ethnic, religious, or sacred uses pertinent to this project area which could be significantly affected.

2. Historic Buildings

No. See No.# 1 above.

3. Ethnic Cultural Values

No. See No.# 1 above.

4. Religious/Sacred Uses

No. See No.# 1 above.

U. Mandatory Findings of Significance

1. Environmental Quality Degradation

No. The open pile designed pier and its rock cribbed pierhead will be reconstructed in its footprint. There will be about a four week period during reconstruction when the indigenous aquatic biota will be displaced but will recolonize and return to normal after the project is completed. The project activities will occur during the non fish spawning season between July 1 and October 1. Mitigation measures, including turbidity screens or caissons or vertical sleeves and the use of tarps to intercept spills will be incorporated to protect Lake Tahoe during the reconstruction phase of the operation. With the mitigation measures incorporated into the reconstruction process, this project will not create any long term significant degradational environmental effects.

The continued use of the two existing buoys will not create any new significant environmental effects. TRPA regulations stipulate that the buoys and their chains will be pulled during the non boating (buoy mooring) season between October 1 and May 15.

2. Short Term vs. Long Term Environmental Goals

No. There will be a short term, approximately four weeks, disruption of the marine environment in the immediate vicinity of the pier and boathouse are being reconstructed in their own footprint. This area will be isolated by a turbidity screen or the use of caissons or vertical cylinders (sleeves) to prevent the release of resuspended sediments during pile placement activities as determined by TRPA. Upon completion of the project, the indigenous marine biota will re-colonize and fill any voids created during the pier reconstruction. There will not be any new long term significant degradational environmental changes created by the reconstruction project or the continued use of the two existing mooring buoys.

3. Cumulative Impacts

No. The Feibusch family's two existing buoys, recreational pier and boathouse are all existing facilities. Their continued use and repair/reconstruction in their own footprint will not add to nor create any new impacts which will increase the propensity for considerable cumulative effects

for considerable cumulative effects.

4. Adverse Effects on Human Beings

No. The continued use of the two existing buoys and the reconstruction of the pier and boathouse in their own footprint will not create any new environmental effects which could create a significant adverse effect on human beings.

CALENDAR PAGE	107
MINUTE PAGE	1952

BUOYS: Distances Relative to:

Pier: 75' Buoy 1 -
95' Buoy 2

Adjacent Pier: North - 295'
& Buoy: South - 220'

Property Lines: North - 55'
South - 140'

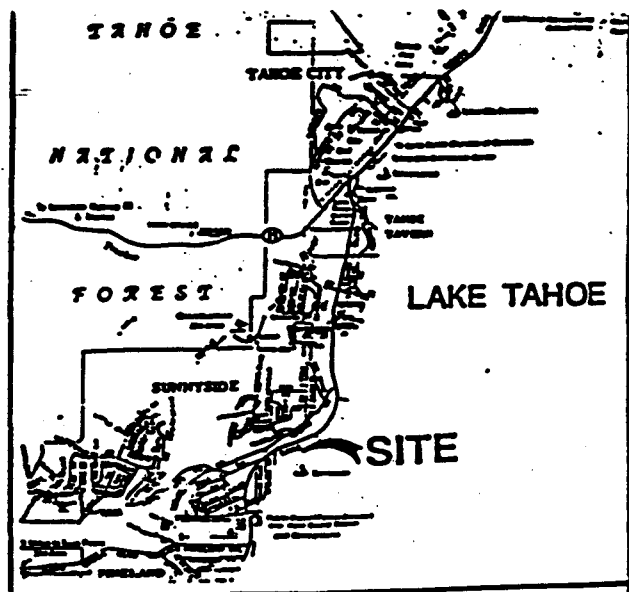

LOCATION MAP

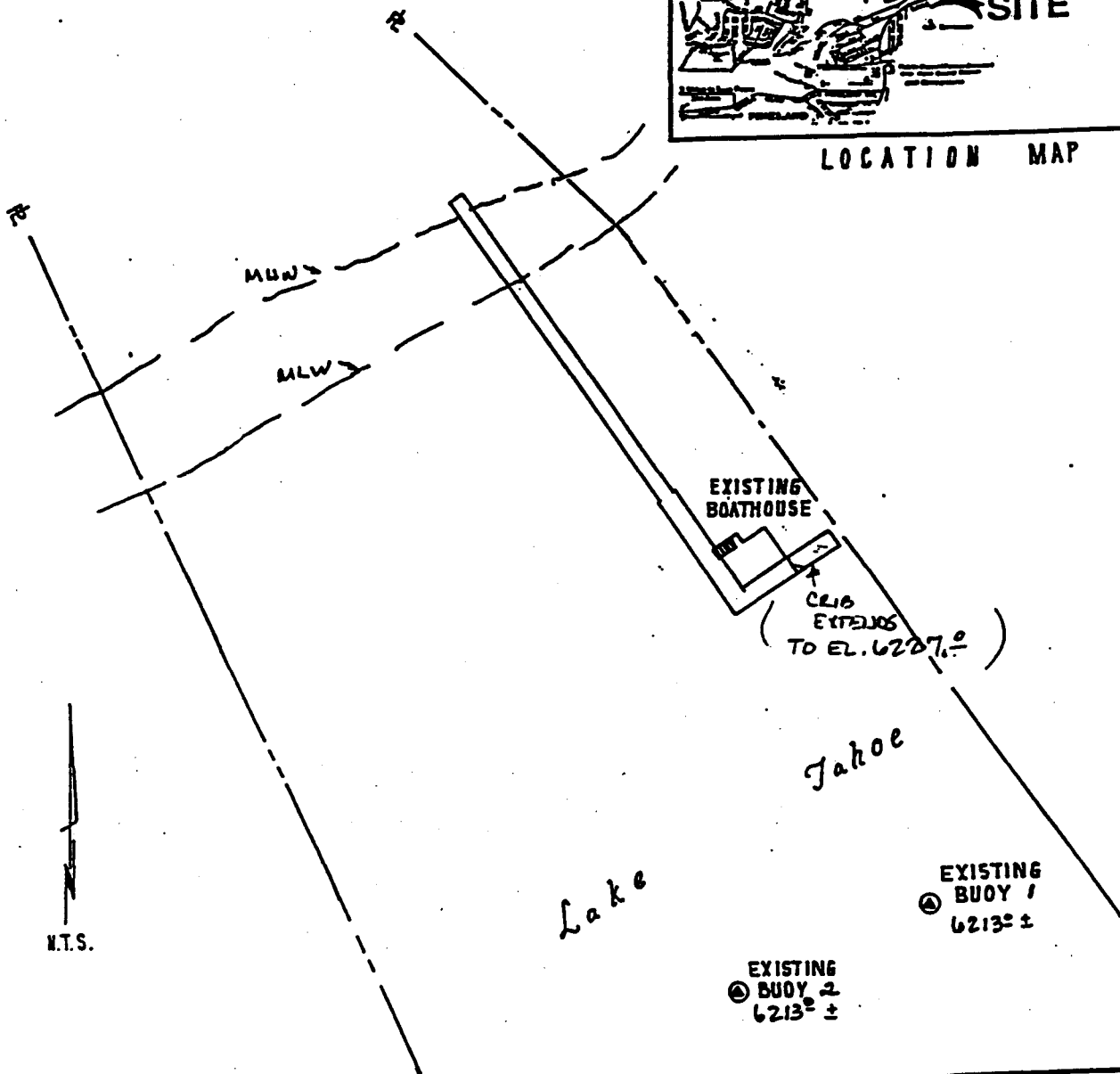

N.T.S.

ADJOINING PROPERTIES:

SOUTH: 83-162-15, GATES
NORTH: 83-162-20, WILLIAMS

PIER & BOATHOUSE RECONSTRUCTION

1310 WEST LAKE BLVD.
A.P.N. 83-162-03
PLACER COUNTY, CALIFORNIA

BRISCO ENTERPRISES

APPLICATION BY:

REIBUSCH

CALENDAR PAGE	108
MINUTE PAGE	SHEET 1953

EXHIBIT A

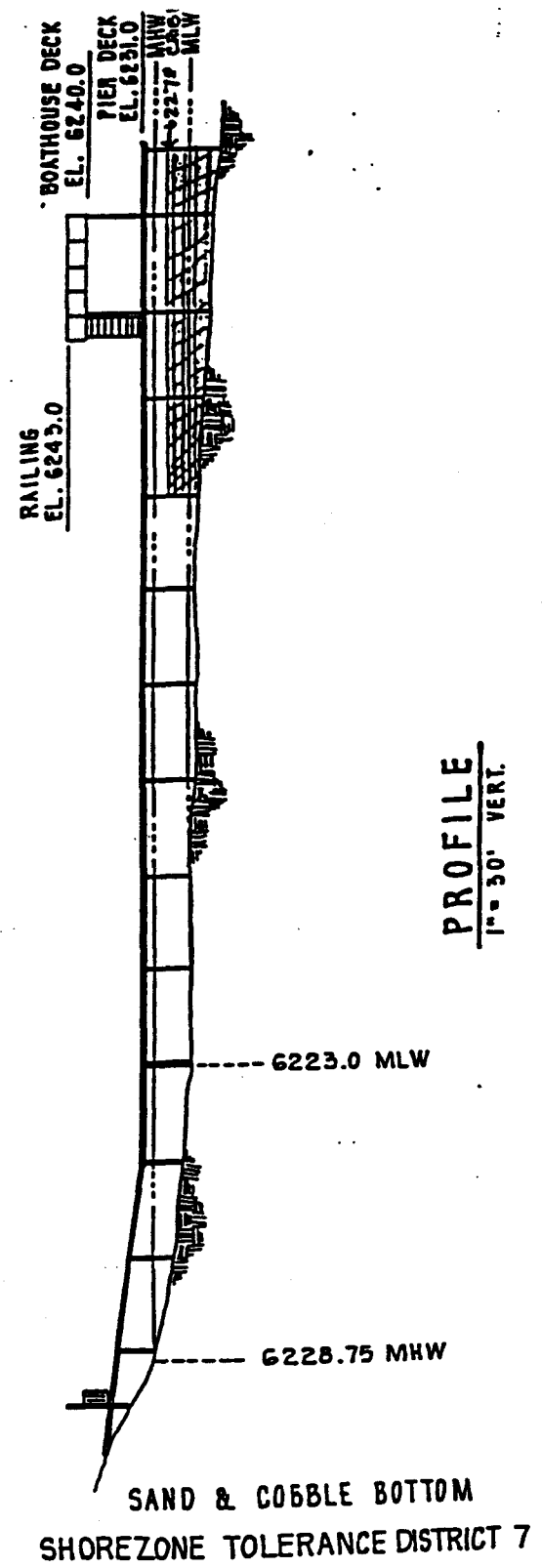
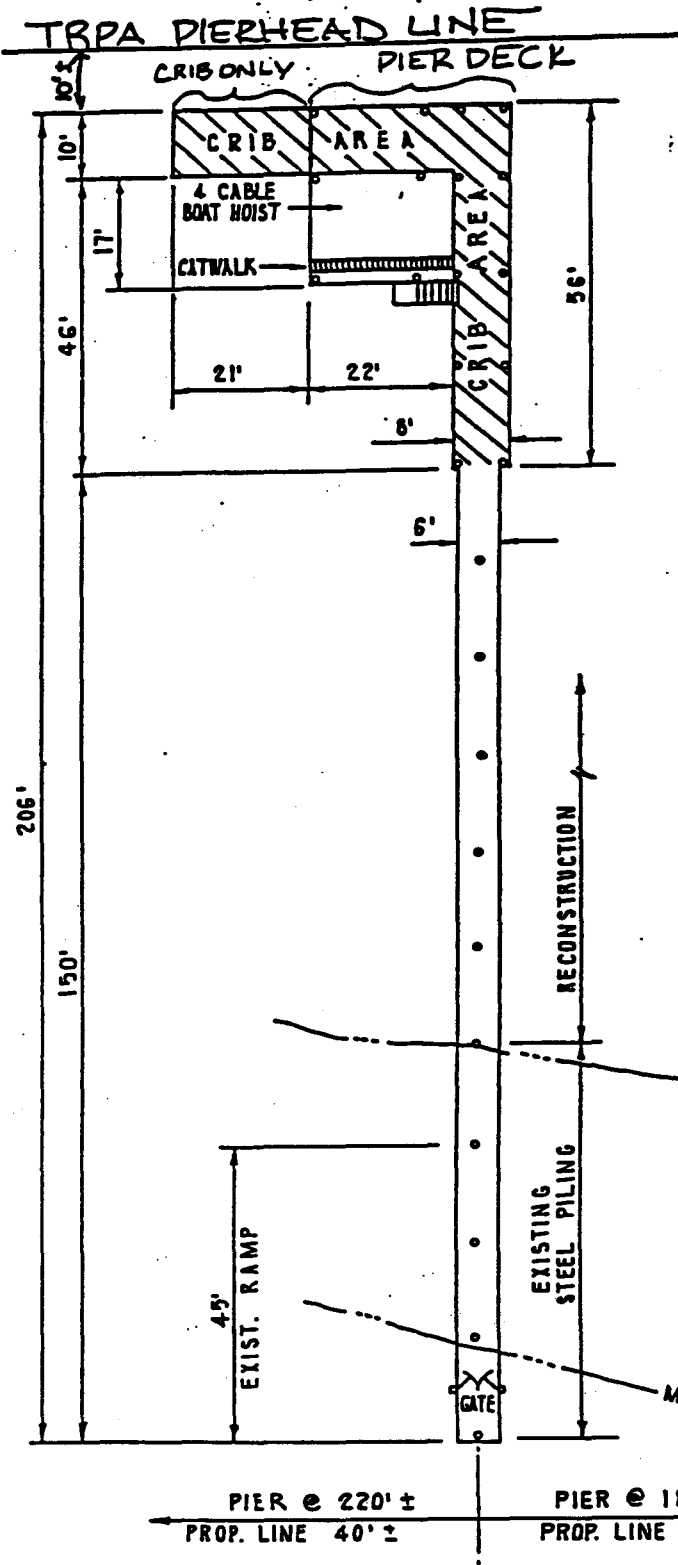

ADJOINING PROPERTIES:
SOUTH : 83-162-15 , GATES
NORTH : 83-162-20 , WILLIAMS

PIER & BOATHOUSE RECONSTRUCTION
1310 WEST LAKE BLVD.
A.P.N. 83-162-03
PLACER COUNTY , CALIFORNIA

CALENDAR PAGE 109
MINUTE PAGE EXHIBIT 1954

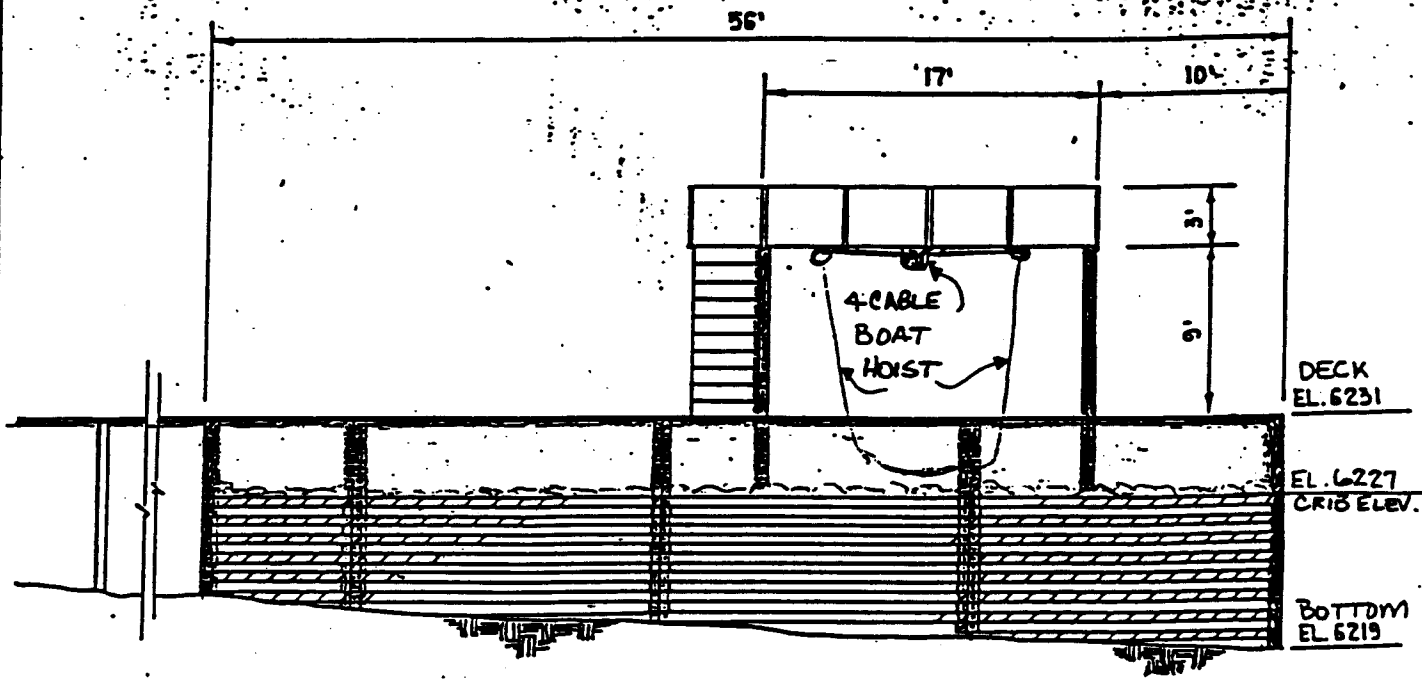

TYPICAL CRIB PROFILE

SCALE : 1" = 10' VERT & HORIZ.
 (REPAIR CRIB TO ELEVATION 6227° LTD.)

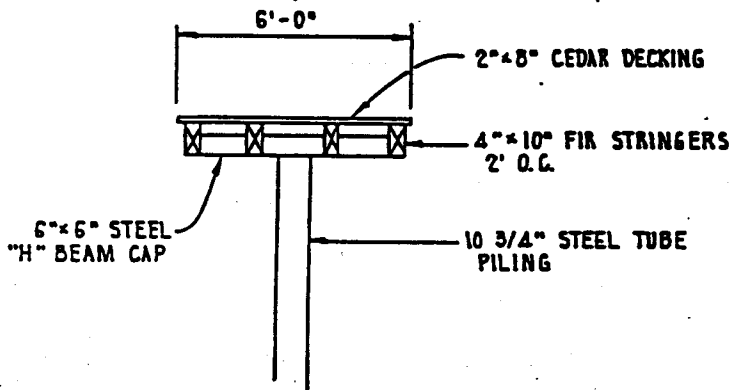

**TYPICAL 6' SECTION
 T-TYPE CONSTRUCTION**

ADJOINING PROPERTIES:
 SOUTH : 83-162-15 , GATES
 NORTH : 83-162-20 , WILLIAMS

PIER & BOATHOUSE RECONSTRUCTION
 1310 WEST LAKE BLVD.
 A.P.N. 83-162-03
 PLACER COUNTY , CALIFORNIA

BRISCO ENTERPRISES

APPLICATION BY :
 FEIBUSCH

CALENDAR PAGE	110
MINUTE PAGE	1955

EXHIBIT "B"
MONITORING PROGRAM
FOR THE FEIBUSCH PIER AND BOATHOUSE RECONSTRUCTION PROJECT

1. **Impact:** The proposed project may cause minimal turbidity to lake waters during the driving of piling into the lake bed, and there is the possibility of an upset or spill of construction materials or debris.

Project Modification:

- a) The use of either a turbidity screen surrounding the project area will be installed prior to the commencement of operations or the use of caissons or vertical cylinders (sleeves) to prevent the release of resuspended sediments during pile placement activities will be determined by TRPA prior to construction;
- b) Small boats and/or tarps will be placed under the reconstruction area as necessary to collect construction debris; and,
- c) Waste materials will be collected onto the lark vehicle or dumpsters for disposal at an approved landfill site.

Monitoring:

Staff of the State Lands Commission, or its designated representative, will periodically monitor the pier reconstruction and boat lift project during the placement of the pilings.

2. **Impact:** The proposed project is located in designated fish spawning habitat and could have an impact on the habitat.

Project Modification:

The pier reconstruction project involving disturbance to the lake bed will be conducted during the non-spawning season, identified to be between July 1 - October 1, to reduce impacts to fish habitat.

2. **Impact:** The proposed project is located in designated fish spawning habitat and could have an impact on the habitat.

Project Modification:

The pier reconstruction project involving disturbance to the lake bed will be conducted during the non-spawning season, identified to be between July 1 - September 15, to reduce impacts to fish habitat.

Monitoring:

Staff of the State Lands Commission, or its designated representative, will periodically site inspect the pier reconstruction project to ensure the proposed activity will occur within the allowable construction time period.