

MINUTE ITEM  
This Calendar Item No. C06  
was approved as Minute Item  
No. 06 by the State Lands  
Commission by a vote of 3  
to 0 at its 7-19-93  
meeting.

CALENDAR ITEM

C06

A 1  
S 2

07/19/93  
W 24865  
PRC 3186  
Gordon

TERMINATION OF LEASE NO. 3186.1 P.R.C. SERIES,  
GENERAL LEASE - RIGHT OF WAY USE PRC 3186  
AND ISSUANCE OF GENERAL LEASE - RIGHT-OF-WAY USE

**APPLICANT:**

Louisiana - Pacific Corporation  
P.O. Box 158, 1 L-P Drive  
Samoa, California 95564

**AREA, TYPE LAND AND LOCATION:**

A 9.045-acre area and an 18.089-acre area of tide and submerged land located in the Pacific Ocean adjacent to the Samoa Peninsula near Eureka, Humboldt County.

**LAND USE:**

Extension, reconstruction, operation and maintenance of an existing 48-inch inside diameter wastewater discharge outfall pipeline utilized in the processing of woodchips into bleached pulp for commercial purposes, and for a temporary construction easement, respectively.

**ORIGINAL LEASE TERMS:**

Lease period:

15 years beginning October 22, 1964.

Provisions re: additional periods:

3 successive periods of 10 years each.

Surety bond:

\$5,000.

Consideration:

\$911.55 per annum; five-year rent review.

CALENDAR PAGE	53
MINUTE PAGE	1208

**AMENDMENT OF ORIGINAL LEASE TERMS:**

Lease period:  
30 years beginning October 22, 1979.

Surety bond:  
\$5,000.

Public liability insurance:  
Combined single limit coverage of \$300,000.

Consideration: \$2,563.20 per annum.

**PROPOSED LEASE TERMS:**

Lease period:  
30 years beginning July 22, 1993.

Surety bond:  
\$25,000.

Public liability insurance:  
Combined single limit coverage of \$1,000,000.

**Special:**

1. The lease terminates the original lease and amendment thereto.
2. Following completion of the project, as determined by Lessor, Lessor shall prorate the monetary considerations for the temporary construction, which has been paid in full at the time of Lessee's execution of the lease, on the basis of the total length time Lessee utilizes the easement area for all project activities.
3. Prior to commencing construction, Lessee will provide for Lessor's consideration and approval, three copies of each of the following: 1) final approved project plans; 2) the final approved installation schedule; and 3) the project contractor's Critical Operations and Curtailment Plan.
4. Lessee will provide copies of the project "as built" plans and post construction report within 120 days following completion of the project.
5. Lessee will provide information regarding Lessee's post construction inspection program and operational inspection report.

CALENDAR PAGE	54
MINUTE PAGE	1209

CALENDAR ITEM NO. C06 (CONT'D)

6. Lessee agrees to notify staff prior to making any repairs of or modifications to the facilities as described within the lease.

**CONSIDERATION:**

\$5,064 for the period beginning July 22, 1993, ending July 21, 1994; and \$6,314.40. per annum, thereafter, as to the permanent right of way; subject to review on each fifth anniversary of the Lease.

**OTHER CONSIDERATION:**

\$26,455, as to the temporary construction easement; subject to proration based on the length of time the easement area is utilized for all project activities.

**BASIS FOR CONSIDERATION:**

Pursuant to 2 Cal. Code Regs. 2003.

**APPLICANT STATUS:**

Applicant is owner of upland.

**PREREQUISITE CONDITIONS, FEES AND EXPENSES:**

Filing fee, processing costs, and environmental cost have been received.

**STATUTORY AND OTHER REFERENCES:**

A. P.R.C.: Div. 6, Parts 1 and 2; Div. 13.

B. Cal. Code Regs.: Title 3, Div. 3; Title 14, Div. 6.

**AB 884:**

N/A

**OTHER PERTINENT INFORMATION:**

1. This is an application to amend Applicant's existing lease for the purpose of extending the authorized 48-inch inside diameter wastewater discharge outfall pipeline an additional 5,210 feet with the attachment of a 36-inch inside diameter concrete-coated steel pipeline. To facilitate the operation of the existing pipeline and the extension as a single unit, a 36-inch outside diameter polyethylene liner will be inserted through the length of the existing pipeline and its existing diffuser to the point of connection with the proposed extension.

CALENDAR PAGE	55
MINUTE PAGE	1210

CALENDAR ITEM NO. C06 (CONT'D)

In 1989, the U.S. Department of Justice filed an enforcement action on behalf of the U.S. Environmental Protection Agency (EPA) in federal court alleging that Applicant had repeatedly violated the National Pollution Discharge Elimination System permit for its Samoa Mill, which currently discharges processed wastewater into the ocean via the existing outfall pipeline. Additionally, the Surfrider Foundation filed a Clean Water Act citizen's suit against Applicant alleging similar permit violations. Both lawsuits focused on allegations that the Samoa Mill violated effluent limits for chronic toxicity and narrative standards protecting recreational users of the Pacific Ocean. In 1991, Applicant entered into a Consent Decree with the Department of Justice and the other referenced plaintives to settle both suits. In 1992, Applicant negotiated a modification of said decree which establishes the depth at which effluents will be discharged from the subject extension. Under the Consent Decree, Applicant has agreed to come into compliance with chronic toxicity limits and to extend the subject existing potential impacts of said ocean waters outfall pipeline to minimize the effluent on recreational users and the adjacent beach.

2. At its October 22, 1964 meeting, in Minute Item 7, the Commission authorized the issuance of Lease No. 3186.1 P.R.C. Series, dated November 24, 1964, to Georgia Pacific Corporation for the existing outfall pipeline.

At its March 29, 1973 meeting, in Minute Item 4, the Commission approved the assignment of Lease No. 3186.1 P.R.C. Series from Georgia Pacific Corporation to Louisiana-Pacific Corporation.

At its June 26, 1980, meeting, in Minute Item 9, the Commission approved the amendment and renewal of the above-referenced lease in the format of General Lease - Right-of-Way, PRC 3186.1, dated June 26, 1980 for the existing outfall pipeline. To facilitate the issuance of the proposed new lease agreement, which is consistent with the Commission's current rules and regulations, termination of the original lease and amendments thereto is recommended. The termination and replacement of the original lease and amendment are

CALENDAR PAGE	56
MINUTE PAGE	1211

for administrative purposes and to accommodate the enlargement of the estate beyond that granted in said earlier agreements.

3. This activity involves lands identified as possessing significant environmental values pursuant to P.R.C. 6370, et seq. Based upon the staff's consultation with the persons nominating such lands and through the CEQA review process, it is the staff's opinion that the project, as proposed, is consistent with its use classification.

**APPROVALS OBTAINED:**

County of Humboldt.

**FURTHER APPROVALS REQUIRED:**

California Coastal Commission; North Coast Regional Water Quality Control Board and United States Army Corps of Engineers.

**EXHIBITS:**

- A. Land Description
- B. Location Map
- C. Local Government Comment
- D. California Environmental Quality Act (CEQA) Findings
- E. Mitigation Monitoring Plan
- F. Humboldt County Planning Commission Resolution  
No. 13-93
- G. Notice of Determination

**IT IS RECOMMENDED THAT THE COMMISSION:**

1. FIND THAT AN EIR WAS PREPARED AND CERTIFIED FOR THIS PROJECT BY THE COUNTY OF HUMBOLDT AND THAT THE COMMISSION HAS REVIEWED AND CONSIDERED THE INFORMATION CONTAINED THEREIN.
2. ADOPT THE FINDINGS MADE IN CONFORMANCE WITH SECTION 15096(h) OF THE STATE CEQA GUIDELINES, AS CONTAINED IN EXHIBIT "D", ATTACHED HERETO.
3. ADOPT THE MITIGATION MONITORING PLAN, AS CONTAINED IN EXHIBIT "E", ATTACHED HERETO.
4. FIND THAT THIS ACTIVITY IS CONSISTENT WITH THE USE CLASSIFICATION DESIGNATED FOR THE LAND PURSUANT TO P.R.C. 6370, ET SEQ.

CALENDAR ITEM NO. C06 (CONT'D)

5. AUTHORIZE TERMINATION OF LEASE NO 3186.1 P.R.C. SERIES, DATED NOVEMBER 24, 1964, AND GENERAL LEASE - RIGHT-OF-WAY, PRC 3186.1, DATED JUNE 26, 1980, EACH EFFECTIVE JULY 22, 1993 AND THE ISSUANCE TO LOUISIANA - PACIFIC CORPORATION OF A 30-YEAR GENERAL LEASE - RIGHT-OF-WAY BEGINNING JULY 22, 1993; IN CONSIDERATION OF RENT IN THE AMOUNT OF \$5,064 FOR THE PERIOD BEGINNING JULY 22, 1993, ENDING JULY 21, 1994; AND \$6,314.40 PER ANNUM, THEREAFTER, AS TO THE PERMANENT RIGHT-OF-WAY; WITH THE STATE RESERVING THE RIGHT TO FIX A DIFFERENT RENTAL ON EACH FIFTH ANNIVERSARY OF THE LEASE; AND OTHER CONSIDERATION IN THE AMOUNT OF \$26,455, AS TO THE TEMPORARY CONSTRUCTION EASEMENT, SUBJECT TO PRORATION BASED ON THE TOTAL LENGTH OF TIME THE EASEMENT AREA IS UTILIZED FOR ALL PROJECT ACTIVITIES; WITH A PROVISION OF A \$25,000 SURETY BOND; AND A PROVISION OF PUBLIC LIABILITY INSURANCE FOR COMBINED SINGLE LIMIT COVERAGE OF \$1,000,000; FOR THE EXTENSION, RECONSTRUCTION, OPERATION, AND MAINTENANCE OF AN EXISTING 48-INCH INSIDE DIAMETER WASTEWATER DISCHARGE OUTFALL PIPELINE UTILIZED IN THE PROCESSING OF WOODCHIPS INTO BLEACHED PULP FOR COMMERCIAL PURPOSES; AND FOR A TEMPORARY CONSTRUCTION EASEMENT, ALL ON THE LAND DELINEATED ON EXHIBIT "A" ATTACHED AND BY REFERENCE MADE A PART HEREOF.

CALENDAR PAGE	58
MINUTE PAGE	1213

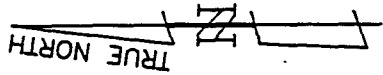
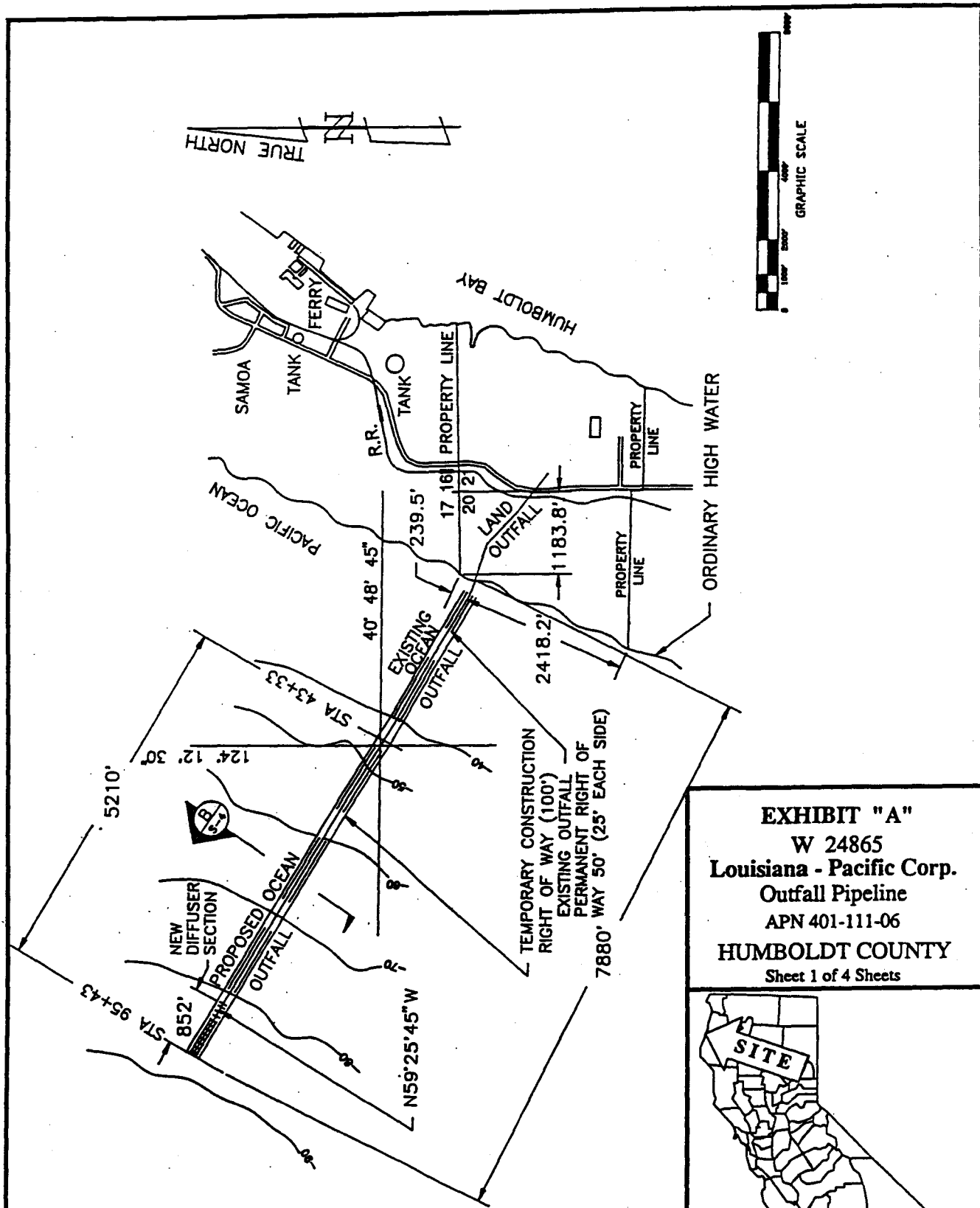
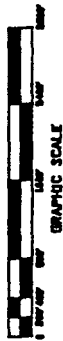
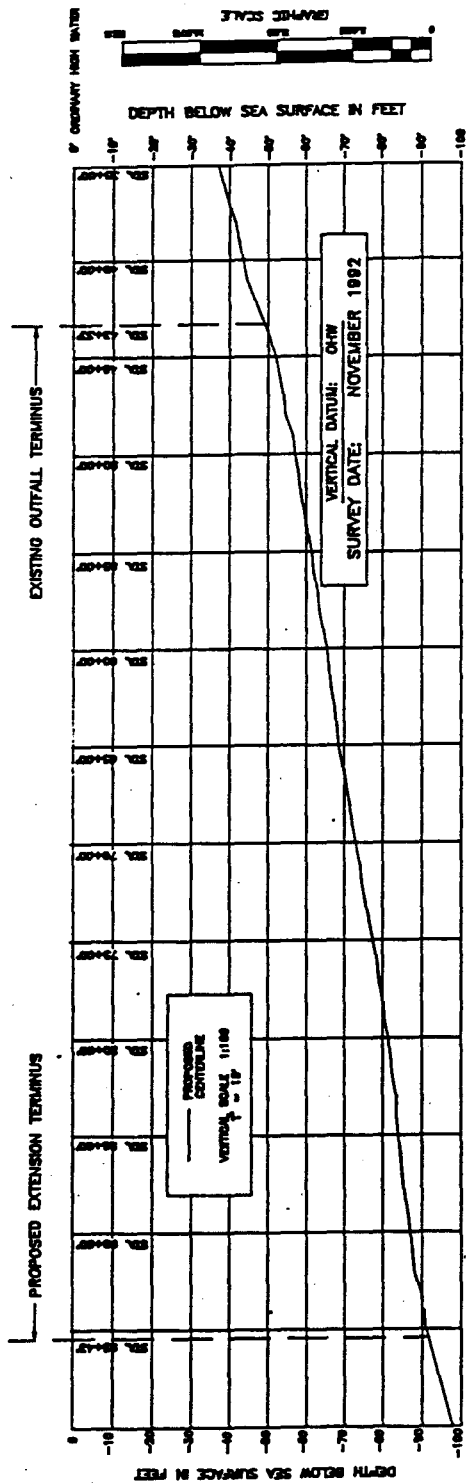

**EXHIBIT "A"**  
 W 24865  
 Louisiana - Pacific Corp.  
 Outfall Pipeline  
 APN 401-111-06  
 HUMBOLDT COUNTY  
 Sheet 1 of 4 Sheets



This Exhibit is solely for purposes of generally defining the lease premises, and is not intended to be, nor shall it be construed as, a waiver or limitation of any State interest in the subject or any other property.

CALENDAR PAGE	59
MINUTE PAGE	1214



I.D. OUTFALL EXTENSION PROFILE

NOTES:

1. ALL EXISTING PLAN & PROFILE DATA WAS PROVIDED BY LOUISIANA-PACIFIC DRAWING 007-801-8. NO FIELD SURVEY OR VERIFICATION WORK WAS PERFORMED BY EIS.
2. STATION LOCATION OF "ORDINARY HIGH WATER" CALCULATED FROM DATA PROVIDED BY DRAWING 007-801-8 WITH ORDINARY HIGH WATER BEING 2'-0" ABOVE MSL.
3. STATIONS IN 100' INCREMENTS.

**EXHIBIT "A"**  
**W 24865**  
**Louisiana - Pacific Corp.**  
**Outfall Pipeline**  
**APN 401-111-06**  
**HUMBOLDT COUNTY**  
 Sheet 2 of 4 Sheets

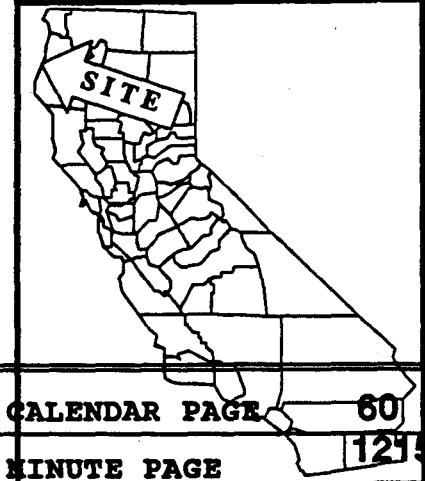

This Exhibit is solely for purposes of generally defining the lease premises, and is not intended to be, nor shall it be construed as, a waiver or limitation of any State interest in the subject or any other property.



This Exhibit is solely for purposes of generally defining the lease premises, and is not intended to be, nor shall it be construed as, a waiver or limitation of any State interest in the subject or any other property.

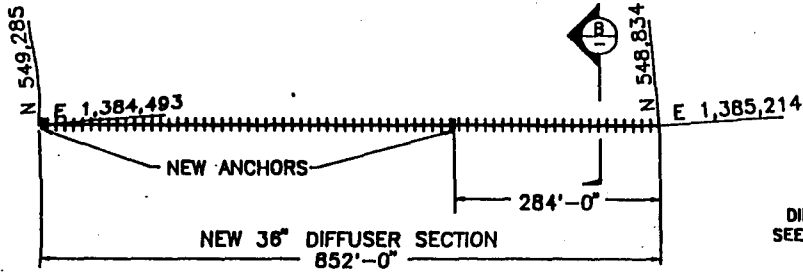

**DIFFUSER LOCATION**

NO SCALE

NOTE: NAD 27 CALIFORNIA ZONE 1

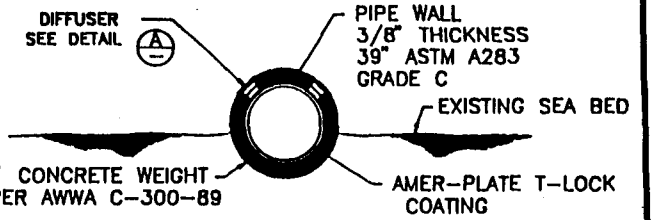

**PIPE SECTION (B)**  
SCALE: 1/8" = 1'-0"

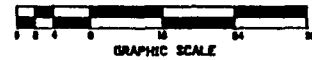

72 PAIRS OF NOZZLES  
SPACED 12'-0" O/C  
ALONG DIFFUSER  
SEE DETAIL (B)

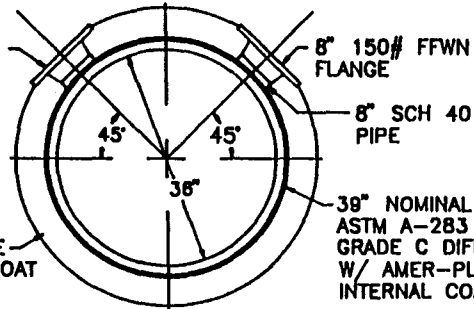

36" NOMINAL STD WEIGHT  
ASTM A-283  
GRADE C DIFFUSER PIPE  
W/ AMER-PLATE T-LOCK  
INTERNAL COATING

**DIFFUSER DETAIL (A)**  
SCALE: 1/2" = 1'-0"

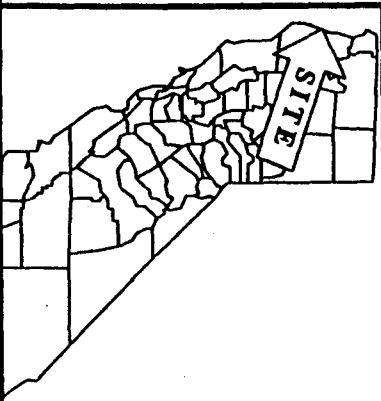

**EXHIBIT "A"**  
W 24865  
Louisiana - Pacific Corp.  
Outfall Pipeline  
APN 401-111-06  
HUMBOLDT COUNTY  
Sheet 3 of 4 Sheets

CALENDAR PAGE 61  
MINUTE PAGE 1215  
CG 5/93

- NOTES:
1. ALL EXISTING PLAN & PROFILE DATA WAS PROVIDED BY LOUISIANA-PACIFIC DRAWING D07-661-S. NO FIELD SURVEY OR VERIFICATION WORK WAS PERFORMED BY DS.
  2. STATION LOCATION OF "ORDINARY HIGH WATER" CALCULATED FROM DATA PROVIDED BY DRAWING D07-661-S WITH "ORDINARY HIGH WATER BEING 2'-0" ABOVE MSL.
  3. STATIONS IN 100' INCREMENTS.

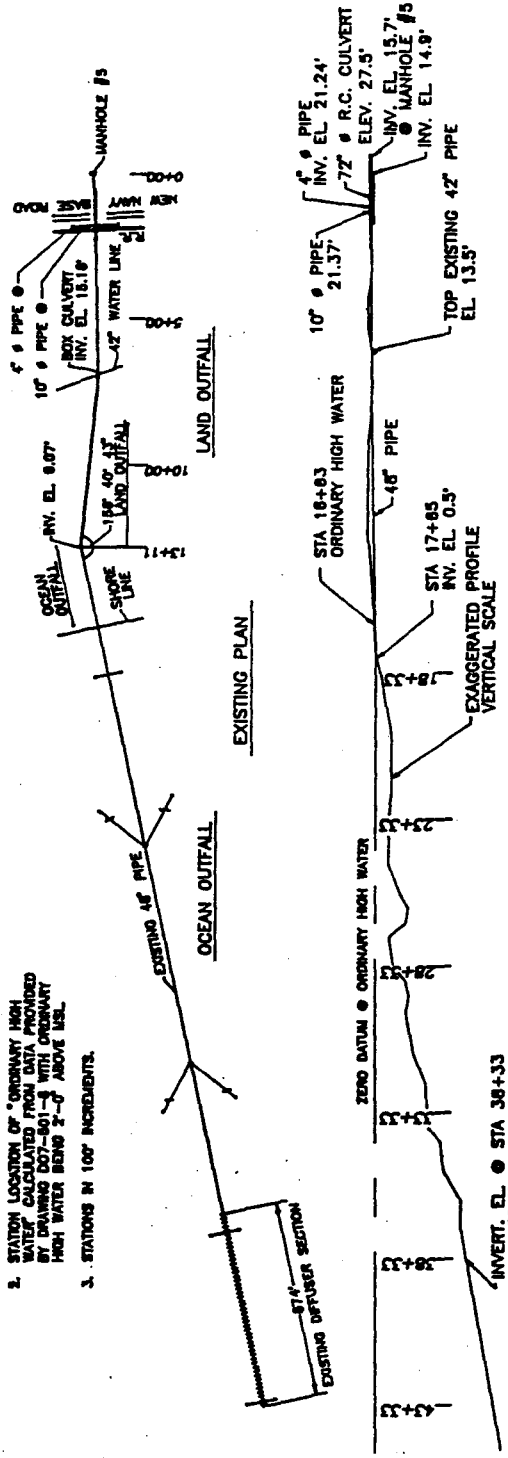

EXISTING OUTFALL PROFILE



**EXHIBIT "A"**  
 W 24865  
 Louisiana - Pacific Corp.  
 Outfall Pipeline  
 APN 401-111-06  
 HUMBOLDT COUNTY  
 Sheet 4 of 4 Sheets



This Exhibit is solely for purposes of generally defining the lease premises, and is not intended to be, nor shall it be construed as, a waiver or limitation of any State interest in the subject or any other property.

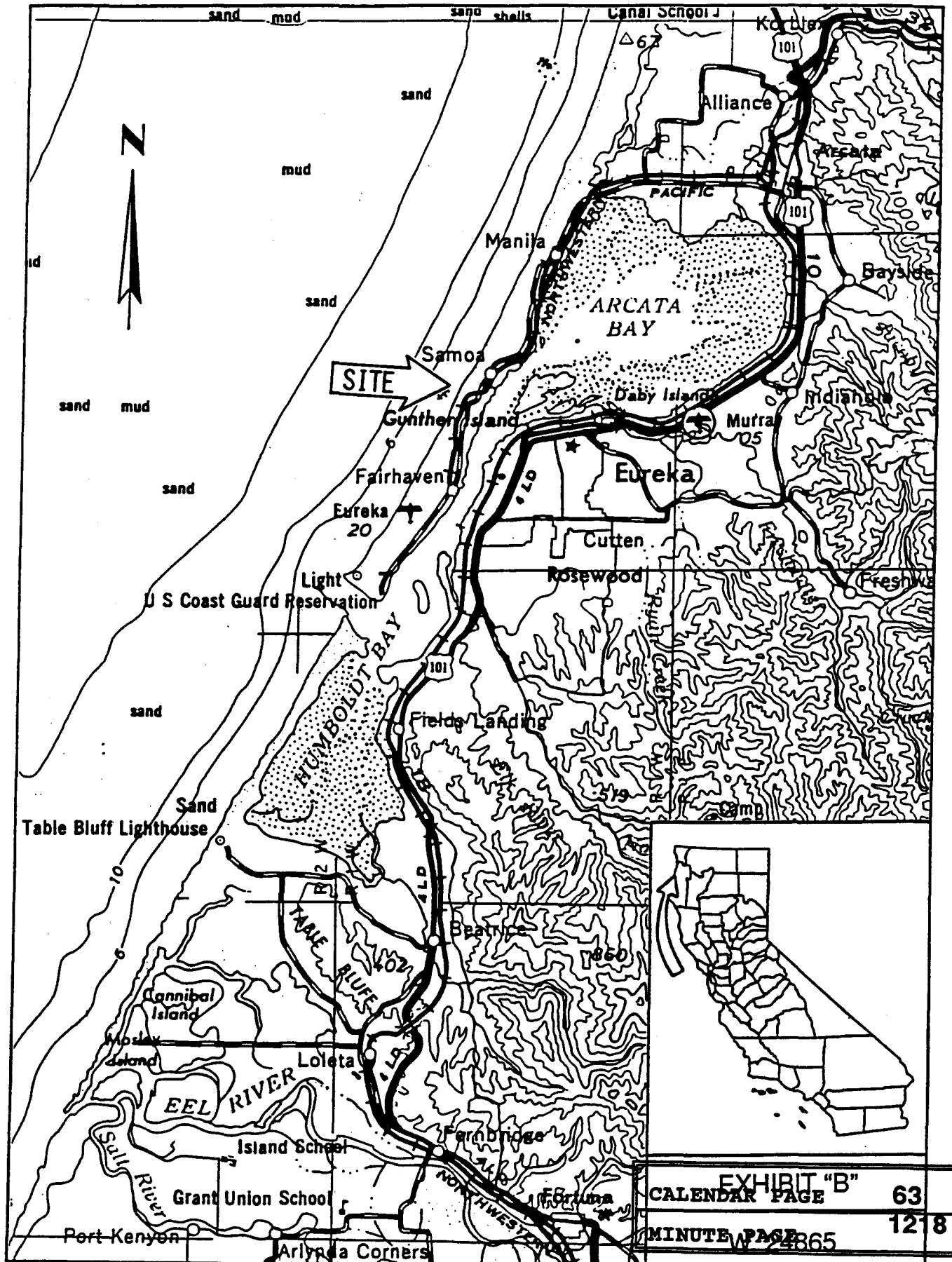

EXHIBIT "B"	63
CALENDAR PAGE	1218
MINUTE PAGE	24865

EXHIBIT "C"

Applicants Name: LOUISIANA - PACIFIC (L-P) APN 401-111-06 ( Samoa Area) Case Nos: CUP-20-92/CDP-20-92/SP-69-92

REVISED
AGENDA ITEM TRANSMITTAL

TO: HUMBOLDT COUNTY PLANNING COMMISSION

FROM: Thomas D. Conlon, Director of Planning and Building

Table with 3 columns: Meeting Date (MAY 27, 1993), SUBJECT: Public Hearing Item ( ) Consent Agenda CONDITIONAL USE PERMIT/COASTAL DEVELOPMENT PERMIT AND SPECIAL PERMIT, CONTACT: ROBERT LONDON

Before you is the following:

PROJECT: Conditional Use Permit, Coastal Development Permit and Special Permit. Application for three independent projects, collectively known as the Louisiana-Pacific Corporation Pollution Prevention Project. The component projects and objectives are: 1) steam stripping of foul condensates to reduce effluent toxicity and odor, and to comply with BOD and pH limitations; 2) installation of tankage and other process modifications to allow for substitution of other bleaching compounds for chlorine in the bleaching process to produce absolute chlorine-free (ACF) pulp, to reduce effluent color and chronic toxicity, and to improve worker safety by elimination hazardous chlorine storage and use; and 3) extension of the existing wastewater discharge outfall to a greater depth and greater distance offshore to provide more effective mixing, and much less frequent discoloration of the ocean surface.

PROJECT LOCATION: The L-P Samoa Mill and project site is located on the North Spit of the Samoa Peninsula, which lies between the Pacific Ocean on the west and Humboldt Bay to the east in Humboldt County, California.

PRESENT PLAN DESIGNATIONS: Industrial/Coastal Dependent (MC), Industrial General (MG) and Natural Resources (NR); Humboldt Bay Area Plan

PRESENT ZONING: Industrial/Coastal Development/Archaeological Resource (MC/A), Industrial General (MG) and Natural Resource/Coastal Wetlands, Dune and Beach Areas (NR/W,B)

ASSESSOR PARCEL NUMBERS: APN401-111-06, 401-111-07, and 401-112-07

APPLICANT Attn: James P. Miller Louisiana-Pacific Corporation 1 L-P Drive/P.O. Box 158 Samoa, CA 95564 (707)443-7511
OWNER(S)
AGENT

ENVIRONMENTAL REVIEW: [X] Review required per the State CEQA Guidelines. [ ] Categorically exempt per Class Section of the State CEQA Guidelines.

MAJOR ISSUES [ ] None [X] Air and water quality, sensitive habitat.
STATE APPEAL STATUS: Appealable to the California Coastal Commission.

RECOMMENDATION: 1. Hold a Public Hearing. 2. Review the staff report and accept testimony on the proposed project and the associated Final Environmental Impact Report. 3. Certify the Final Environmental Impact Report in accordance with the California Environmental Quality Act by adoption of Resolution No. 13-93 by roll call vote. 4. Approve the project based on the findings in the staff report and as conditioned by Exhibit A.

RECORD OR ACTION: [ ] Approved as recommend by the Planning and Building Department [ ] Approved with the attached revisions.

Adopted after review and consideration of all the evidence on May 27, 1993 The motion was made by Bish and seconded by Brown

AYES: Commissioners: Bish, Brown, Eitzen, Feeney, Kirby
NOES: Commissioners: None
ABSTAIN: Commissioners: None
ABSENT: Commissioners: Sorensen

I, THOMAS D. CONLON, Secretary to the Planning Commission of the County of Humboldt, do hereby certify the foregoing to be a true and correct record of the action taken on the above entitled matter by said Commission at the meeting held on the Date noted above.

THOMAS D. CONLON, Humboldt County Director of Planning and Building
By: YVETTE TUCKER

Last day to appeal to Humboldt County Board of Supervisors: Friday, June 11, 1993, 5:00 p.m.

Table with 2 columns: CALENDAR PAGE 64, MINUTE PAGE 1219

cc: [ ] Applicant [ ] Owner [ ] Agent (if any) [ ] Public Works [ ] Calif. Coastal Commission
(Conv205,sub1,lp.ait, word) (TDA:RL:vn) LOUISIANA- PACIFIC (LP) Report Date: 5/18/93 Page

## EXHIBIT A

**APPROVAL OF THE COASTAL DEVELOPMENT, CONDITIONAL USE PERMIT, AND SPECIAL PERMIT IS CONDITIONED ON THE FOLLOWING TERMS AND REQUIREMENTS:**

1. The applicant shall secure a Coastal Development Permit from the California Coastal Commission for that portion of the project within their jurisdiction.
- 2a. The applicant shall request a written statement and provide it to the Humboldt County Planning Division from the California Regional Water Quality Control Board - NorthCoast ("RWQCB-NC") stating that the project as proposed, revised and/or conditioned complies with/will comply with rules, regulations, and/or requirements of the RWQCB-NC. (See Exhibit D for agency comments).
- 2b. The applicant shall request a written statement and provide it to the Humboldt County Planning Division from the NorthCoast Unified Air Quality Management District ("NCUAQMD") stating that the project as proposed, revised and/or conditioned complies with/will comply with rules, regulations, and/or requirements of the NCUAQMD. (See Exhibit D for agency comments).
- 2c. The applicant shall request a written statement and provide it to the Humboldt County Planning Division from the California Coastal Commission ("CCC") stating that the project as proposed, revised and/or conditioned complies with/will comply with rules, regulations, and/or requirements of the CCC. (See Exhibit D for agency comments).
- 2d. The applicant shall request a written statement and provide it to the Humboldt County Planning Division from the U.S. Army Corps of Engineers ("COE") stating that the project as proposed, revised and/or conditioned complies with/will comply with rules, regulations, and/or requirements of the COE. (See Exhibit D for agency comments).
- 2e. The applicant shall request a written statement and provide it to the Humboldt County Planning Division from the U.S. Department of Commerce, National Oceanic and Atmospheric Administration, National Marine Fisheries Service ("NMFS") stating that the project as proposed, revised and/or conditioned complies with/will comply with rules, regulations, and/or requirements of NMFS, (See Exhibit D for agency comments).
- 2f. The applicant shall request a written statement and provide it to the Humboldt County Planning Division from the U. S. Environmental Protection Agency ("EPA") stating that the project as proposed, revised and/or conditioned complies with/will comply with rules, regulations, and/or requirements of EPA. (See Exhibit D for agency comments).
- 2g. The applicant shall request a written statement and provide it to the Humboldt County Planning Division from State Lands Commission ("SLC") stating that the project as proposed, revised and/or conditioned complies with/will comply with rules, regulations, and/or requirements of the SLC. See Exhibit D for agency comments).

TURN PAGE

- 2h. The applicant shall request a written statement and provide it to the Humboldt County Planning Division from the California Department of Fish and Game ("CDF&G") stating that the project as proposed, revised and/or conditioned complies with/will comply with rules, regulations, and/or requirements of CDF&G. (See Exhibit D for agency comments).
- 2i. The applicant shall request a written statement and provide it to the Humboldt County Planning Division from the Humboldt Bay Municipal Water District ("HBMWD") stating that the project as proposed, revised and/or conditioned complies with/will comply with rules, regulations, and/or requirements of HBMWD. (See Exhibit D for agency comments).
- 2j. The applicant shall request a written statement and provide it to the Humboldt County Planning Division from the Fairhaven Fire Protection District ("FFPD") stating that the project as proposed, revised and/or conditioned complies with/will comply with rules, regulations, and/or requirements of FFPD. (See Exhibit D for agency comments).
- 2k. The applicant shall request a written statement and provide it to the Humboldt County Planning Division from the Humboldt County Division of Environmental Health ("DEH") stating that the project as proposed, revised and/or conditioned complies with/will comply with rules, regulations, and/or requirements of DEH. (See Exhibit D for agency comments).
- 2l. The applicant shall request a written statement and provide it to the Humboldt County Planning Division from the Humboldt County Building Inspection Division ("BID") stating that the project as proposed, revised and/or conditioned complies with/will comply with rules, regulations, and/or requirements of BID. (See Exhibit D for agency comments).
- 2m. The applicant shall request a written statement and provide it to the Humboldt County Planning Division from the Humboldt County Department of Public Works, Real Property Division ("RPD") stating that the project as proposed, revised and/or conditioned complies with/will comply with rules, regulations, and/or requirements of the RPD. (See Exhibit D for agency comments).
3. The project shall be developed, operated, regulated, and maintained as described by Exhibit A (Conditions of Approval), Exhibit B (Final EIR, Section 6, Mitigation and Monitoring Program, Pages 6-1 to 6-12, inclusive) and Exhibit C (Project Description).
4. Minor deviations from the approved project which do not raise any substantive environmental issues may be authorized by the Planning Director by means of a Special Permit with the advice and consent of all applicable advisory and/or regulatory agencies.
5. Minor deviation from the plot plan shall adhere to the dimensional limitations and procedures specified by Humboldt County Code A315-20.

TURN PAGE

6. For purposes of ensuring compliance with the project as proposed and conditioned and to provide a multitude of agencies, decision makers, and the local community with an opportunity to comprehensively follow the progress of the pioneering Absolutely Chlorine-Free (ACF) conversion process, the applicant shall prepare a Post Project Approval Evaluation Report ("Report"). At a minimum, the Report should consider:
- A. The author of Report shall contact all regulatory and advisory agencies (to be identified by the Planning Division) to include their comments on information to be included in the report either to be generated by the author or as may be provided by the agency.
  - B. The Report should provide quantifiable data, as available, on such areas of concerns as water quality, air quality, and sensitive habitat protection.
  - C. The Report should focus on compliance with agency requirements and the approved Mitigation Program.
  - D. The Report shall be prepared annually for the next three (3) years with the first report due April 1, 1994 and subsequent reports due by April 1 of the following year.
  - E. The Report is intended to be a factual accounting of progress towards implementation of the project and is generally not intended as a vehicle for additional technical analysis.
  - F. Additional details regarding the content of the Report shall be formulated by the Humboldt County Planning Division in concert with L-P and public agencies identified by 6A, above, by October 30, 1993.
  - G. The author of the Report shall be present at an annual review of the Report before the Planning Commission, (to be scheduled), to present the report and respond to questions (The annual reviews are intended as an informative public workshop lasting 30 to 60 minutes at most).
  - H. The second annual report should address the issues associated with an extended shutdown (one year or more) or the permanent cessation of operations as a pulp mill. This section of the Report should be formulated in concert with appropriate agencies to effect a safe and orderly process. (Note: Permanent closure of the Samoa mill is not contemplated.)
7. A filing fee of Eight Hundred and Seventy-Five Dollars (\$875.00) must be paid to the County Clerk at 825 Fifth Street, Room 235 in Eureka. A copy of your receipt must be submitted to the Planning Division to satisfy this condition. This fee is required by state law to cover the cost of the Department Fish and Game's environmental review of your project.

TURN PAGE

EXHIBIT "C"

8. The applicant shall fully reimburse the County of Humboldt for the costs of implementing the conditions of approval.
9. The applicant shall provide at least one copy of the certified, final EIR to each responsible agency.

END



EXHIBIT "D"

Attachment A

STATEMENT OF FINDINGS AND FACTS

LOUISIANA-PACIFIC CORPORATION  
POLLUTION PREVENTION PROJECT

I. SUMMARY OF PROPOSED PROJECT

The Louisiana-Pacific Corporation (L-P) Pollution Prevention Project is described in Section 2 of the Final EIR, and a detailed project description is included as Exhibit C to the Staff Report. In summary, the proposed project would: (1) extend the existing ocean outfall line about 4,400 feet farther offshore to a discharge depth of 82 feet (25 meters); (2) install chemical storage tanks necessary for process modifications to allow the elimination of chlorine-based pulp bleaching and to recycle the bleach plant effluent to the existing recovery furnace; and (3) install a steam stripping system for the foul condensate waste stream. The project would make the Samoa mill the first pulp mill in the United States to produce absolutely chlorine-free (ACF) pulp on a full-time basis.

The three components of the project are required under a Consent Decree entered into by L-P, the U.S. Department of Justice, the U.S. Environmental Protection Agency (EPA), and the Surfrider Foundation. The Consent Decree settled an EPA enforcement action and Clean Water Act citizen's suit alleging that L-P had repeatedly violated the wastewater discharge permit for the Samoa mill. The proposed project is expected to enable the Samoa mill to comply with all applicable water quality standards.

L-P's overall project objective is to ensure compliance with applicable legal requirements, eliminate or minimize potential environmental impacts associated with the existing effluent discharge, and improve receiving water quality. L-P has identified the following specific project objectives:

- Reduce effluent toxicity and comply with applicable chronic toxicity limitations;
- Protect recreational beneficial uses of the Pacific Ocean adjacent to the Samoa Peninsula;
- Comply with national effluent limitations for Biochemical Oxygen Demand (BOD) and pH and thereby eliminate the need for the variance from those limits authorized by Section 301(m) of the Clean Water Act;
- Eliminate the discharge of dioxin and all other chlorinated organic compounds and comply with the California Ocean Plan water quality objective for dioxin;
- Reduce effluent color and comply with the California Ocean Plan's light transmittance

CALENDAR PAGE	69
MINUTE PAGE	1224

standard and prohibition on undesirable aesthetic discoloration of the ocean surface;

- Reduce effluent odor;
- Improve worker and public safety by eliminating the use of all chlorine compounds in the pulp production process;

## II. IMPACTS DETERMINED NOT TO BE SIGNIFICANT OR MITIGATED TO A LESS THAN SIGNIFICANT LEVEL

The potential environmental effects associated with the project are discussed in Sections 4.0 and 7 of the Final EIR. The project would not result in any unavoidable significant adverse environmental impacts. Potentially significant adverse effects have been eliminated or substantially lessened to a level of insignificance by virtue of project design considerations and the mitigation measures identified in the Final EIR and included as conditions of project approval.

### A. Earth

#### Potential Impacts

The project's potential impacts on soils and geology that can be mitigated or are otherwise not significant are discussed in Section 4.1 of the Final EIR. The steam stripping system and the chemical storage tanks for ACF pulp production would be constructed in previously disturbed and graded areas of the Samoa mill. Construction activities related to transportation of the outfall extension pipeline from the mill to the beach would require grading of approximately 0.6 acres of previously disturbed coastal dunes. Pulling of the pipeline offshore and hydraulic jetting to bury the outfall extension would temporarily disturb ocean bottom sediments.

#### Findings

1. Changes or alterations have been required in, or incorporated into, the project which avoid or substantially lessen the potential significant environmental effects identified in the Final EIR.

2. The effects identified in the Final EIR have been determined not to be significant.

#### Facts in Support of Findings

The project's potential impacts to soils and geology have been eliminated or substantially lessened to a level less than significant by virtue of project design considerations and the mitigation measures identified in the Final EIR and incorporated into the project. The mitigation measures are as follows:

CALENDAR PAGE as 70  
MINUTE PAGE 1225

Project design would conform to the Geologic Hazards Land Use matrix in the General Plan. L-P shall submit foundation design drawings to the Department of Planning and Building Inspection for review and approval prior to construction.

L-P has submitted a dune stabilization and revegetation plan for review and approval by the Department of Planning and Building Inspection. L-P shall implement the approved dune stabilization and revegetation plan to reduce erosion impacts during project construction. After completion of construction, L-P shall recontour and revegetate all dune areas in accordance with the approved plan.

The potential hazard to project facilities due to ground failure resulting from strong earthquake shaking or due to a tsunami runup would be low. The risk of damage would be the same as those to existing mill facilities.

A bathymetric survey and geotechnical engineering design study has been conducted for the outfall extension. The seafloor along the outfall extension corridor slopes gently (less than one percent) toward the west-northwest. The seabed survey found no significant breaks in the slope and no high relief features. The ocean bottom contours are subject to natural variation, and the natural movement of sandy sediments would recontour the ocean bottom areas disturbed during construction.

#### B. Air Quality

##### Potential Impacts

The project's potential impacts on air quality that are not significant are discussed in Sections 4.2 and 7 of the Final EIR. Two components of the project will result in increases in atmospheric emissions. First, compounds removed from the foul condensates in the steam stripping system will be incinerated in an existing thermal oxidizer unit (TOU). Second, compounds recovered from the ACF bleaching process will be incinerated in the existing recovery boiler. Cumulative air emissions from the project would not exceed applicable ambient air quality standards for any criteria air pollutants, except for particulates known as PM-10. Based on worst-case assumptions, the PM-10 standard would occasionally be exceeded because the Humboldt County area has been designated as non-attainment for PM-10 under existing conditions.

##### Findings

1. The effects identified in the Final EIR have been determined not to be significant.

2. Specific economic, social, or other considerations make infeasible the mitigation measures or project alternatives. **CALENDAR PAGE 71**

identified in the EIR.

Facts in Support of Findings

The North Coast Unified Air Quality Management District (Air District) is the responsible agency for ensuring that air emissions from the Samoa mill, including emissions from the proposed project, comply with applicable requirements of the Federal Clean Air Act, the California Clean Air Act, and the implementing regulations. The Air District will review L-P's application for a permit to authorize project air emissions. In addition, EPA will review proposed modifications to air emissions from the recovery furnace associated with the conversion to ACF production.

The proposed steam stripping system will be integrated into the existing TOU. At the request of the Air District, the cumulative emissions from the existing TOU and the proposed steam stripper have been evaluated. The cumulative air quality analysis in the EIR, which also considers emissions related to ACF production, is a necessary part of the Air District's permitting review.

Project impacts on air quality, including cumulative impacts, were addressed by evaluating the impacts on ambient air quality of maximum permitted increases in emissions using an EPA-approved method. The expected upper limit of emissions for each contaminant was used, together with assumptions of conservative atmospheric dispersion, in determining worst-case ambient air quality impacts.

Cumulative emissions of sulfur dioxide (SO<sub>2</sub>) from the project and the existing TOU would trigger review by the Air District under the so-called Prevention of Significant Deterioration (PSD) provisions of the Federal Clean Air Act. However, cumulative emissions of SO<sub>2</sub> would not exceed applicable ambient air quality standards for this pollutant. In its comments on the Draft EIR, the Air District found that "Ambient impacts due to the increase in sulfur dioxide will not be significantly increased."

Cumulative emissions of nitrogen dioxide would not exceed applicable ambient air quality standards for this pollutant. In its comments on the Draft EIR, the Air District found that "Ambient impacts due to the increase in nitrogen dioxide will not be significant."

The Humboldt County area has been designated as non-attainment for PM-10, based on observed ambient air quality levels which occasionally exceed the California 24-hour PM-10 standard (measured levels do not exceed the federal PM-10 standards). Given this non-attainment status, on a worst case basis, cumulative emissions of PM-10 from the project would occasionally exceed applicable ambient air quality standards for this pollutant. However, project emissions would be

On a worst case basis, cumulative emissions of PM-10 from the project would occasionally exceed applicable ambient air quality standards for this pollutant. However, project emissions would be	72
MINUTE PAGE	1227

below the applicable PSD threshold, and ambient air quality impacts would be below the allowable PSD increments for ambient air quality. Moreover, after project implementation, particulate emissions from the Samoa mill will continue to be approximately 50% of the existing permit limit established by the Air District for this pollutant. Based on these considerations, project emissions would not cause or substantially contribute to additional violations of ambient air quality standards for PM-10.

Under existing conditions, stack emissions from the recovery furnace have resulted in occasional reported violations of the plume opacity standard contained in Air District Rule 410(d). The validity of the Rule 410(d) opacity standard has been challenged in litigation. Moreover, L-P and Air District have not resolved the technical causes for the violations. In any event, opacity can be considered only a surrogate for particulate emissions, including PM-10. As discussed above, after project implementation, particulate emissions from the Samoa mill will continue to be approximately 50% of the existing permit limit established by the Air District.

The project would result in a significant net reduction in carcinogenic risk due to the elimination of chlorinated organic compounds, including chloroform and dioxin.

Under the project, a chelant will be added between the oxygen delignification system and the wash process steps to bind metal ions in order to keep them from interfering with the ACF process. Preliminary research indicates that the chelant and associated metals must be purged from the bleaching process and routed to the effluent. However, the EIR includes a worst-case air quality analysis that assumes the metals presently discharged to the sewer would instead be transported to the recovery furnace (where the chelant would be destroyed), subjected to electrostatic precipitator control, and emitted into the air.

The total effect of potentially increased metals emissions would be to increase the chronic hazard index by 0.00013. This is a small fraction of the existing chronic hazard index of 1.8. In contrast, the removal of chlorine compounds from ACF production would reduce the existing chronic hazard index by 0.02, resulting in a net reduction in the chronic hazards from the project. The acute hazard index is below 1.0 under existing conditions and would be reduced by about 0.004 from the removal of chlorine compounds.

The steam stripping system would reduce odorous emissions (primarily total reduced sulfur compounds) by an estimated 95%.

During upset conditions, when the noncondensable gases and steam stripper product cannot be routed to the incinerator, this stream would be routed to a flare or if existing lime kiln for incineration. Flaring

to the incinerator, CALENDAR CASE to the 73
would replace total 1228
MINUTE PAGE

reduced sulfur emissions with sulfur dioxide. Any sulfur dioxide emissions from flaring would be below ambient air quality standards for this pollutant.

The increases in air emissions from the project, although not significant, are unavoidable. No mitigation measures are available to reduce emissions associated with the steam stripper, which would be a state-of-the-art system, or the existing TOU, which also includes state-of-the-art emissions controls. The increased incineration of black liquor solids from ACF production, and resulting increases in air emissions, are an unavoidable result of recovering these waste constituents from the effluent.

Alternative 1, the No Project Alternative, would avoid the air quality impacts associated with the proposed project. However, the No Project Alternative is infeasible because this alternative would not achieve any of the basis project objectives. See the analysis of the No Project Alternative in the section on Alternatives to the Proposed Project, below.

Alternatives 4 and 5, which include secondary treatment, steam stripping, and chlorine bleaching, would avoid the air quality impacts associated with the conversion to ACF production, including the increases in PM-10 emissions. However, these alternatives would result in potentially significant nitrogen dioxide, sulfur dioxide, and PM-10 emissions, and a potential increase in carcinogenic risk from formation of chlorinated hydrocarbons because of incineration of the sludge generated by secondary treatment. These alternative would also result in a potential new source of odors from operation of secondary treatment ponds. In addition, Alternatives 4 and 5 would result in potentially significant impacts that would not occur with the proposed project, such as the permanent disturbance of approximately 40 acres of land for construction of secondary treatment ponds. Because Alternatives 4 and 5 generally would result in greater impacts than the project, and would not meet a number of important project objectives, these alternative are rejected as infeasible. See the analysis of Alternatives 4 and 5 in the section on Alternatives to the Proposed Project, below.

### C. Water Quality

#### Potential Impacts

The project's potential impacts on water quality that are not significant are discussed in Section 4.3 of the Final EIR. The project is intended to eliminate or minimize potential environmental impacts associated with the existing effluent discharge from the Samoa mill and improve receiving water quality. Operation of ACF pulp bleaching and steam stripping would reduce the amount of pollutants discharged in the ocean and improve compliance with water quality standards for effluent toxicity, color, odor, BOD, and pH. The outfall extension would

CALENDAR PAGE	74
NOTE PAGE	1229

improve compliance with water quality standards by improving dilution rates. Therefore, the project's impacts on water quality would be beneficial.

Finding

1. The effects identified in the Final EIR have been determined not to be significant.

Facts in Support of Finding

The three project components are required under a Consent Decree entered into to address and resolve water quality concerns at the Samoa mill. The proposed project is intended to enable the Samoa mill to comply with all applicable water quality standards.

The North Coast Regional Water Quality Control Board (Regional Board) is the responsible agency for ensuring that the wastewater from the Samoa mill complies with applicable requirements of the Federal Clean Water Act and the California Porter-Cologne Water Quality Act. The current Regional Board permit contains an extensive monitoring program requiring L-P to evaluate a wide range of effluent characteristics and the potential for adverse effects on the marine environment and recreational uses. The Regional Board is in the process of developing a new discharge permit for the Samoa mill, which will be issued for public review and comment within the next several months. The new permit will contain effluent limits and monitoring requirements similar to those in the existing permit.

The project would substantially reduce effluent toxicity and ensure that the Samoa mill complies with applicable permit limits for toxicity. In comparison to toxicity levels observed with normal chlorine bleaching, during full-scale ACF trials the toxicity as measured by the sea urchin test was reduced by 74 to 95%. The ACF trials did not include recycle of the wastewater from the bleach plant, which would be implemented after completion of the proposed project and further reduce effluent toxicity.

Based on treatability pilot studies, steam stripping would reduce the toxicity of the foul condensate waste stream, as measured using the sea urchin test, by an average of approximately 75% from existing condition. Given the contribution of the foul condensates to the toxicity of whole effluent, steam stripping would reduce the toxicity of the whole effluent by approximately 30%.

The new outfall and diffuser design would increase the degree of effluent dilution at the edge of the zone of initial dilution (ZID) in the ocean. For a given effluent composition, extension of the outfall would reduce the concentration of toxicants at the edge of the ZID by approximately 40%. Because regulatory criteria required by EPA and the Regional Board apply

MINUTE PAGE	75
	1230

at the edge of the ZID, this increased initial dilution will enhance L-P's ability to meet applicable water quality standards, including permit limits for toxicity.

ACF bleaching would eliminate the formation and discharge in the effluent of all chlorinated organic compounds, including dioxins.

During the full-scale ACF trials, the color of the effluent was reduced an average of approximately 75% in comparison to existing conditions. The ACF trials did not include recycle of the wastewater from the bleach plant and recovery of the solids in the filtrate for incineration, which would be implemented after completion of the proposed project and further reduce effluent color.

Steam stripping would reduce the total reduced sulfur compounds in the foul condensates, which are the primary source of effluent odor, by approximately 95%. As a result, the project would substantially reduce the odor of the effluent in comparison to existing conditions.

Based on treatability pilot studies and the results of full-scale ACF trials, ACF pulp production in combination with steam stripping would substantially reduce the BOD of the effluent and enable the Samoa mill to comply with existing national effluent limits for BOD. The ACF trials have also demonstrated that ACF production would stabilize the pH of the effluent and enable the Samoa mill to comply with existing national effluent limits for pH. Therefore, L-P would no longer need the variance from those effluent limits granted by the Samoa mill's existing wastewater discharge permit, which was issued under Section 301(m) of the Clean Water Act. L-P has withdrawn its application to renew the existing Section 301(m) permit and has applied to the Regional Board for a traditional wastewater discharge permit.

Construction of the outfall extension would result in short-term suspension of seabed sediments during pulling of the pipeline from shore and hydraulic jetting operations to bury the pipeline. The natural movement of sandy sediments would recontour the ocean bottom areas disturbed during construction.

#### D. Terrestrial Biological Resources

##### Potential Impacts

The project's potential impacts on terrestrial biological resources that can be mitigated or are otherwise not significant are discussed in Section 4.4 of the Final EIR. Construction activities related to transportation of the outfall extension pipeline from the mill to the beach would disturb approximately 1.1 acres of previously disturbed coastal dune habitats and would temporarily disturb foraging habitat for shorebirds. Numerous patches of beach layia, a plant protected

CALENDAR PAGE	76
MINUTE PAGE	1231



under both the California and Federal Endangered Species Acts, occur within the outfall extension construction corridor and could be adversely affected by project construction.

### Findings

1. Changes or alterations have been required in, or incorporated into, the project which avoid or substantially lessen the potential significant environmental effects identified in the Final EIR.

2. The effects identified in the Final EIR have been determined not to be significant.

3. Specific economic, social, or other considerations make infeasible the mitigation measures or project alternatives identified in the EIR.

### Facts in Support of Findings

The project's potential impacts to terrestrial biological resources have been eliminated or substantially lessened to a level less than significant by virtue of project design considerations and the mitigation measures identified in the Final EIR and incorporated into the project. The mitigation measures are as follows:

L-P has submitted a dune stabilization and revegetation plan for review and approval by the Department of Planning and Building Inspection. L-P shall implement the approved dune stabilization and revegetation plan to reduce erosion impacts during project construction. After completion of construction, L-P shall recontour and revegetate all dune areas in accordance with the approved plan. The plan shall require L-P to re-seed or plant beach layia in appropriate habitat to maintain and enhance the populations of this species within the construction corridor. L-P shall prepare and implement a revegetation monitoring plan after construction of the outfall extension.

L-P shall flag the patches of beach layia found within the construction corridor prior to construction of the outfall extension and shall avoid or minimize disturbance to the plants within the flagged areas during construction.

An onshore and offshore construction monitoring shall be provided during construction of the outfall extension to ensure compliance with construction plans.

The construction corridor for the outfall extension has been previously disturbed as a result of repair and maintenance of the existing outfall pipe. Adverse impacts to wildlife species from construction of the outfall extension would be

CALENDAR PAGE	77
MINUTE PAGE	1232

short-term. Abundant habitat is available along the Samoa Peninsula for wildlife species adversely affected by project construction. After revegetation of the affected coastal dunes, wildlife species would resume use of areas disturbed during construction.

Field surveys have been conducted to determine whether any plants protected under the California or Federal Endangered Species Acts occur within the construction corridor. With the exception of the beach layia, no protected plant species were found within the construction corridor.

Based on the types of habitat in the vicinity of the construction corridor, the only protected wildlife species that could potentially be impacted by the project would be the western snowy plover. The California Department of Fish and Game (DFG) is currently collecting information on potential nesting locations of the snowy plover in the project area. The findings of DFG, which should be available in mid-June, will be provided to the U.S. Corps of Engineers. As part of the Corps' permitting process for the outfall extension, it will consult with the U.S. Fish and Wildlife Service and DFG under the Federal Endangered Species Act. In the event snowy plovers are found nesting in the vicinity of the pipeline construction corridor, Federal law requires that permit conditions be included in the Corps' permit for the outfall extension providing specific mitigation measures necessary to protect this species.

The potential impacts to the beach layia and other terrestrial resources in the outfall construction corridor, although reduced to a less than significant level by required mitigation measures, are unavoidable under the project. Alternative 1, the No Project Alternative, would avoid the impacts to terrestrial resources, including the beach layia, from the proposed project. However, the No Project Alternative is infeasible because this alternative would not achieve any of the basic project objectives. See the analysis of the No Project Alternative in the section on Alternatives to the Proposed Project, below.

Alternatives 2 and 5, which would not involve construction of the proposed outfall extension, would avoid the impacts to terrestrial resources, including the beach layia, identified for the project. However, these alternatives would not achieve important project objectives, particularly the full protection of recreational beneficial uses of the Pacific Ocean adjacent to the Samoa Peninsula. In addition, construction of a secondary treatment system under Alternatives 5 would result in potentially significant impacts that would not occur with the proposed project, including the permanent disturbance of approximately 40 acres of land for construction of secondary treatment ponds. Because Alternatives 5 generally would result in greater impacts than the project, and because both Alternatives 2 and 5 would not meet important project objectives, these alternative are rejected as infeasible.

CALENDAR PAGE	78
MINUTE PAGE	1233

of Alternatives 2 and 5 in the section on Alternatives to the Proposed Project, below.

E. Marine Biological Resources

Potential Impacts

The project's potential impacts on marine biological resources that can be mitigated or are otherwise not significant are discussed in Section 4.5 of the Final EIR. Construction impacts to marine biological resources would include disturbance of bottom sediments and loss of benthic invertebrates from pipeline pulling, hydraulic jetting, placement of the new diffuser, and anchoring of construction vessels. Offshore construction activities would temporarily disturb commercial and recreational fishing, and could result in spill of oil or gas from construction vessels. Operation of the project would improve the quality of the effluent and, in comparison to existing conditions, would lessen potential impacts on marine biological resources associated with effluent toxicity and bioaccumulation of toxic pollutants.

Findings

1. Changes or alterations have been required in, or incorporated into, the project which avoid or substantially lessen the potential significant environmental effects identified in the Final EIR.

2. The effects identified in the Final EIR have been determined not to be significant.

Facts in Support of Findings

The project's potential impacts to marine biological resources have been eliminated or substantially lessened to a level less than significant by virtue of project design considerations and the mitigation measures identified in the Final EIR and incorporated into the project. The mitigation measures are as follows:

L-P has submitted an anchor mitigation plan for review and approval by the California State Lands Commission (State Lands). L-P shall implement the anchor mitigation plan during construction of the outfall extension to minimize the effects of the anchor mooring system on the ocean bottom.

L-P has submitted a Spill Contingency Plan (SCP) for review and approval by the State Lands. L-P shall implement the SCP during construction of the outfall extension to minimize the risks of any fuel spills on marine life.

Offshore construction activities shall not occur during

CALENDAR PAGE

79

MINUTE PAGE

1234

the intensive commercial crab fishing season, which typically occurs in December and January.

L-P shall submit a Critical Operations and Contingency Plan (COCP) for review and approval by State Lands. L-P shall implement the COCP during construction of the outfall extension to provide additional protection for personnel and the ocean environment during adverse weather and sea conditions.

An onshore and offshore construction monitor shall be provided during construction of the outfall extension to ensure compliance with construction plans.

Construction of the outfall extension would temporarily disturb approximately seven acres of ocean bottom sediments and result in the loss of benthic invertebrates. Since sandy bottom habitat is abundant in the project area, no unique habitat for invertebrate populations would be disturbed. Affected species would recolonize disturbed sandy bottom areas within one year, and there would be no long-term impacts on benthic populations.

Commercial and recreational fishing in the construction area would be affected during the approximately 45-day offshore construction period. The proposed construction period, in either the fall of 1993 or spring of 1994, would avoid the intensive commercial crab fishing season during the winter months and the peak recreational boat fishing season during the summer months. The project would not result in long-term impacts to fish or crab species.

Construction of the outfall extension would not disturb the marine habitat of any bird or mammal species protected under California or Federal law. The sandy bottom habitat disturbed during project construction is not a unique or critical spawning area for fish species.

Improvements in effluent quality from operation of the project would substantially reduce the amount of pollutants discharged in the ocean. Based on treatability pilot studies and the results of full-scale ACF trials, ACF pulp production in combination with steam stripping would substantially reduce the BOD of the effluent. In addition, ACF pulp production would stabilize the pH of the effluent. ACF production and steam stripping also would reduce the toxicity of the effluent, and the increased initial dilution with the outfall extension would reduce the concentration of the effluent at the edge of the zone of initial dilution. As a result, the discharge of effluent from the project would not cause significant adverse effects on marine biological resources.

ACF bleaching would eliminate the formation and discharge of all chlorinated organic compounds, including dioxins. Thus, ACF production will eliminate bioaccumulation of these compounds and human exposure to

MINUTE PAGE 1235

contaminated seafood.

Long-term monitoring of benthic invertebrates and fish populations at the existing L-P diffuser has shown only minor differences in species composition and abundances, and there is no evidence that such differences were due to the effluent. With the project, sedimentation due to particulates in the discharge would cease at the existing diffuser location. The dispersion and settling of particulates from the new diffuser location would occur at a lower rate, but affect a larger area, as a result of the increased initial dilution. Based on prior monitoring and studies of the ocean waters adjacent to the Samoa Peninsula, operation of the project would not have a significant adverse impact on marine biological resources at the new outfall location.

The Regional Board is the responsible agency for ensuring that the wastewater from the Samoa mill complies with applicable requirements of the Federal Clean Water Act and the California Porter-Cologne Water Quality Act. The current Regional Board permit contains an extensive monitoring program requiring L-P to evaluate a wide range of effluent characteristics and the potential for adverse effects on the marine environment and recreational uses. The Regional Board is in the process of developing a new discharge permit for the Samoa mill, which will be issued for public review and comment within the next several months. The new permit will contain effluent limits and monitoring requirements similar to those in the existing permit.

#### F. Transportation and Circulation

##### Potential Impacts

The project's potential impacts on transportation and circulation that can be mitigated or are otherwise not significant are discussed in Section 4.6 of the Final EIR. Project construction would result in short-term increases in traffic volumes on area roads. Vessels working off the Samoa Peninsula for approximately 45 days during construction of the outfall extension may temporarily displace some commercial or recreational boaters.

##### Findings

1. Changes or alterations have been required in, or incorporated into, the project which avoid or substantially lessen the potential significant environmental effects identified in the Final EIR.
2. The effects identified in the Final EIR have been determined not to be significant.

##### Facts in Support of Findings

CALENDAR PAGE	81
MINUTE PAGE	1236

The project's potential impacts to transportation and circulation have been eliminated or substantially lessened to a level less than significant by virtue of project design considerations and the mitigation measure identified in the Final EIR and incorporated into the project. The mitigation measure is as follows:

L-P shall submit a plan for review and approval by the Department of Public Works regarding the repair of New Navy Base Road after completion of project construction.

New Navy Base Road would remain open for public travel during the 10-day period (maximum) required to transport the outfall extension pipeline and new diffuser from the mill site to the beach and offshore project area. Thus, public access to the south end of the North Spit would not be restricted during project construction.

The additional traffic generated during project construction would not exceed the design capacities for any area roads. Once the project is operational, traffic would return to preconstruction levels.

Construction workers would have more than adequate space to park their personal vehicles along I-P Drive.

Offshore construction activities associated with placement of the outfall extension would not occur during the intensive period of commercial crabbing and would not interfere with large commercial marine vessel traffic. Access routes for marine vessels would be available around the construction area. Operation of the project would not affect marine vessel traffic.

#### G. Recreation and Aesthetics

##### Potential Impacts

The project's potential impacts on recreation and aesthetics that are not significant are discussed in Section 4.7 of the Final EIR. Access to the beach area adjacent to the Samoa mill would be limited for approximately four weeks during construction of the outfall extension. In addition, vessels working off the Samoa Peninsula for approximately 45 days during construction of the outfall extension may temporarily displace some recreational boaters. Operation of the project would result in substantial beneficial impacts to recreational users of the Samoa Peninsula.

##### Finding

1. The effects identified in the Final EIR have been determined not to be significant.

##### Facts in Support of Finding

CALENDAR PAGE	82
MINUTE PAGE	1237

Potential adverse impacts to recreational boaters and users of the beach adjacent to the Samoa mill would be short-term during construction of the outfall extension. Abundant beaches and marine fishing areas are available in the vicinity to accommodate recreational users affected by project construction.

New Navy Base Road would remain open for public travel during the 10-day period (maximum) required to transport the outfall extension pipeline and new diffuser from the mill site to the beach and offshore project area. Thus, public access to the south end of the North Spit would not be restricted during project construction.

Steam stripping would reduce the total reduced sulfur compounds in the foul condensates, which are the primary source of effluent odor, by approximately 95%. As a result, the project would substantially reduce the odor of the effluent in comparison to existing conditions.

During the full-scale ACF trials conducted by L-P, the color of the effluent was reduced an average of approximately 75% in comparison to conditions during normal mill operations. The ACF trials did not include recycle of the wastewater from the bleach plant and recovery of the solids in the filtrate for incineration, which would be implemented after completion of the proposed project and further reduce effluent color.

ACF pulp production would eliminate the formation and discharge of chlorinated organic compounds, including dioxin, and substantially reduce the potential for adverse human health effects associated with exposure to the effluent.

Extension of the outfall to a discharge depth of 82 feet would substantially reduce the frequency and concentration of effluent reaching the surf zone along the Samoa Peninsula, including the primary surfing area near the North Jetty.

The mitigation measures listed above for marine biological resources would also reduce any potential adverse impacts to recreational fish resources.

The Regional Board is the responsible agency for ensuring that the wastewater from the Samoa mill complies with applicable legal requirements. The current Regional Board permit contains an extensive monitoring program requiring L-P to evaluate a wide range of effluent characteristics and the potential for adverse effects on recreational users of the marine environment. The Regional Board is in the process of developing a new discharge permit for the Samoa mill, which will be issued for public review and comment within the next several months. The new permit will contain effluent limits and monitoring requirements similar to those in the existing permit.

All project-related visual changes would appear with the

existing boundary of the Samoa mill. The steam stripping system and tanks for ACF bleaching would generally be concealed from public view by existing buildings and industrial structures.

#### H. System Safety and Reliability and Public Health

##### Potential Impacts

The project's potential impacts on system safety and reliability and public health that can be mitigated or are otherwise not significant are discussed in Section 4.8 of the Final EIR. A spill of oil or other substances could potentially occur from vessels operating offshore during construction of the outfall extension. A leak or break in the outfall pipeline due to improper construction could cause effluent to be discharged at locations other than through the new diffuser. As under existing conditions, the potential for spills or upsets to occur at the Samoa mill will remain after completion of the project.

##### Findings

1. Changes or alterations have been required in, or incorporated into, the project which avoid or substantially lessen the potential significant environmental effects identified in the Final EIR.

2. The effects identified in the Final EIR have been determined not to be significant.

##### Facts in Support of Findings

The project's potential impacts on system safety and reliability and public health have been eliminated or substantially lessened to a level less than significant by virtue of project design considerations and the mitigation measures identified in the Final EIR and incorporated into the project. The mitigation measures are as follows:

L-P has submitted a Spill Contingency Plan (SCP) for review and approval by State Lands. L-P shall implement the SCP during construction of the outfall extension to minimize the potential for a spill of oil or other petroleum products to ocean waters.

L-P shall submit a Critical Operations and Contingency Plan (COCP) for review and approval by State Lands. L-P shall implement the COCP during construction of the outfall extension to provide additional protection for personnel and the ocean environment during adverse weather and sea conditions.

An onshore and offshore construction monitor shall be provided during construction of the outfall extension to ensure compliance with construction

CALENDAR PAGE	84
MINUTE PAGE	1239



L-P shall conduct a post-construction survey of the outfall pipeline to verify the pipeline condition and determine whether additional seabed mitigation may be required.

L-P shall conduct an annual pipeline survey to verify the integrity of the pipeline and diffuser.

The elimination of chlorine in the pulp bleaching process would eliminate the hazards to public health and worker safety posed by the storage and use of chlorine under existing conditions. The elimination of chlorine would be a beneficial impact of the proposed project.

L-P has submitted preliminary plans to the County and Regional Board to improve and enhance the existing spill containment system. In particular, the original diked containment area will be expanded to include areas planned for the storage of ACF process chemicals and bleach plant filtrate.

#### I. Utilities and Public Services

##### Potential Impacts

The project's potential impacts on utilities and public services that are not significant are discussed in Section 4.9 of the Final EIR. Operation of project would reduce total water usage at the Samoa mill and may require relatively small increases in the consumption of energy resources. In addition, ACF production would result in small increases in the production of ash requiring disposal.

##### Finding

1. The effects identified in the Final EIR have been determined not to be significant.

##### Facts in Support of Finding

ACF production would reduce the total volume of water used at the Samoa mill by an estimated 3 million gallons per day.

The small amounts of electricity and natural gas that may be required for project operation would not adversely affect regional supplies of these energy resources.

Minor increases in the generation of ash associated with ACF production would not adversely affect the operation of City Garbage of Eureka.

#### J. Socioeconomics

##### Potential Impacts

The project's potential impacts on ~~GENERAL PAGE~~ **85**

are not significant are discussed in Section 4.10 of the Final EIR. Project construction would generate employment and the demand for regional and local goods and services. The project would increase the appraised value of the Samoa mill, resulting in an increase in the property taxes paid by L-P to the County.

#### Finding

1. The effects identified in the Final EIR have been determined not to be significant.

#### Facts in Support of Finding

The increased employment and demand for goods and services associated with project construction would result in beneficial impacts to the regional and local economy. The Eureka area contains adequate guest accommodations and services to meet the needs of any non-local construction workers.

The project would have a beneficial fiscal impact on local government by increasing the appraised value of the Samoa mill and revenues generated by the County from L-P property taxes.

By enabling L-P to comply with applicable legal requirements governing the Samoa mill's effluent discharge, the project would contribute to the continued economic viability of L-P as a major business and employer in the County.

#### K. Cultural Resources

##### Potential Impacts

The project's potential impacts on cultural resources that can be mitigated or are otherwise not significant are discussed in Section 4.11 of the Final EIR. No known archaeological or cultural resources are located on the project site. Nonetheless, construction of the outfall extension could expose previously undiscovered archaeological features.

##### Findings

1. Changes or alterations have been required in, or incorporated into, the project which avoid or substantially lessen the potential significant environmental effects identified in the Final EIR.

2. The effects identified in the Final EIR have been determined not to be significant.

##### Facts in Support of Findings

The project's potential impacts on cultural resources have been eliminated or substantially lessened than significant by virtue of the mitigation measure identified

cultural resources  
CALENDAR PAGE 86  
measure identified 1241  
MINUTE PAGE

in the Final EIR and incorporated into the project. The mitigation measure is as follows:

If any significant archaeological resources are discovered during construction, activities shall be halted until the find can be evaluated by a qualified archaeologist. L-P shall consult with the County to determine whether the find should be photographed and described or retrieved before construction is resumed.

In November 1992, a bathymetric and archaeological survey was conducted in the coastal waters which will be affected by construction and operation of the outfall extension. No prehistoric, historic, or cultural resources were found along the route of the outfall extension.

#### L. Land Use

##### Potential Impacts

The project's conformance with applicable land use plans, policies, and zoning standards is discussed in Section 3.1 of the Final EIR and on pages 2-5 of the Staff Report. The steam stripping system and storage tanks for ACF bleaching would be constructed within the existing Samoa mill industrial facility on private property owned by L-P. Construction of the outfall extension would temporarily disturb public beach areas adjacent to the Samoa mill and submerged State tidelands. The outfall extension and new diffuser would be located on submerged State tidelands.

##### Finding

1. The effects identified in the Final EIR have been determined not to be significant.

##### Facts in Support of Finding

The proposed project would conform with the Planning and Management Policies of the California Coastal Act, the Humboldt Bay Area Plan (HBAP) for the Humboldt County Local Coastal Program, and all applicable Humboldt County Coastal Zoning Regulations. The project is a coastal-dependent industrial use and meets the HBAP Priority 1 site criteria of having existing industrial uses suitable to accommodate the existing or expanded use. In addition, all new project development would be consistent with the adopted Humboldt County Public Safety and Seismic Safety Elements of the General Plan. The proposed project would also be compatible with the zoning designations on the lands surrounding the project site.

### III. ALTERNATIVES TO THE PROPOSED PROJECT

Project alternatives are discussed and

CALENDAR PAGE	87
MINUTE PAGE	1242

Section 5 of the Final EIR. The approach for selecting potential alternatives for detailed analysis in the EIR was to review the results of treatability studies conducted for the Samoa mill. The potential treatment processes were considered in various combinations to estimate relative effectiveness in meeting the basic project objectives. The County has considered the project alternatives identified in the EIR and makes the following findings with respect to those alternatives.

A. Alternative 1: No Project Alternative

The No Project Alternative assumes that operation of the Samoa mill would continue using existing wastewater treatment and discharge facilities.

Finding

Specific economic, social or other considerations make the No Project Alternative infeasible.

Facts in Support of Finding

The No Project Alternative would avoid the potential impacts that are not significant, or can be mitigated to a level of insignificance, identified with the proposed project. However, the No Project Alternative fails to achieve any of the basic objectives of the project. Specifically, the No Project Alternative would not: (1) reduce effluent toxicity and allow the Samoa mill to comply with applicable water quality standards, including applicable chronic toxicity limits; (2) protect recreational beneficial uses of the Pacific Ocean adjacent to the Samoa Peninsula; (3) allow the Samoa mill to comply with applicable national effluent limits for BOD and pH; (4) eliminate the discharge of dioxin and all other chlorinated organic compounds; (5) reduce effluent color; (6) reduce effluent odor; and (7) improve worker and public safety by eliminating the use of all chlorine chemistry in the pulp production process. Therefore, the No Project Alternative is rejected as infeasible.

B. Alternative 2: ACF Production and Steam Stripping; No Outfall Extension

This alternative provides for the conversion of the Samoa mill to ACF production and implementation of steam stripping, but would not include construction of an outfall extension.

Finding

Specific economic, social or other considerations make this alternative infeasible.

Facts in Support of Finding

Alternative 2 would avoid the potential impacts that

CALENDAR PAGE	88
MINUTE PAGES	1243

are not significant, or can be mitigated to a level of insignificance, identified with the construction and operation of the proposed outfall extension. These impacts are related to changes in coastal dune and ocean bottom conditions in the outfall extension construction corridor, disturbance to terrestrial resources, including beach layia populations, from construction of the outfall extension, and effects on marine biological resources from discharge of the effluent at a new diffuser location. This alternative would not reduce the air quality impacts from the project. In addition, this alternative would not achieve two important project objectives. Specifically, this alternative would not: (1) allow the Samoa mill to comply with applicable water quality standards, including applicable chronic toxicity limits; and (2) fully protect recreational beneficial uses of the Pacific Ocean adjacent to the Samoa Peninsula. Therefore, the Alternative 2 is rejected as infeasible.

C. Alternative 3: Proposed Project Plus Metabisulfite Treatment

This alternative consists of the three project components (*i.e.*, ocean outfall extension, conversion to ACF production, and steam stripping), plus the addition of sodium metabisulfite treatment to further reduce effluent toxicity.

Finding

This alternative would not reduce or eliminate any of the adverse environmental effects identified for the proposed project, and specific economic, social or other considerations make this alternative infeasible.

Facts in Support of Finding

Alternative 3 would result in identical potential impacts that are not significant, or can be mitigated to a level of insignificance, identified with the proposed project. This alternative would generally achieve all of the basic objectives of the project. The addition of sodium metabisulfite treatment under this alternative would be intended to further reduce chronic toxicity over those levels estimated for the proposed project. However, testing programs using metabisulfite showed mixed results. Toxicity as measured using the sea urchin would be incrementally reduced beyond levels expected under the project, but increases in toxicity would occur in other test organisms, such as abalone. Because the overall level of toxicity reduction achieved under this alternative might be less than for the proposed project, and because L-P has determined that the addition of metabisulfite treatment is not necessary to comply with the applicable chronic toxicity limits, Alternative 3 is rejected as infeasible.

D. Alternative 4: Secondary Treatment, Steam Stripping, Chlorine Dioxide Bleaching, Outfall Extension

CALENDAR PAGE	89
MINUTE PAGE	1244

This alternative would not involve the conversion to ACF production, but would include secondary treatment and chlorine dioxide bleaching, in addition to steam stripping and an outfall extension to 25 meters. L-P would construct either an oxygen-activated sludge treatment system, which would involve construction of large microbiological reactor tanks, or aerated treatment ponds, which would require approximately 43 acres of land. In addition, L-P would likely use one or more of its presently inactive power boilers to burn the sludge generated from secondary treatment. The bleaching process would involve the elimination of elemental chlorine and increased use of chlorine dioxide.

#### Finding

Specific economic, social or other considerations make this alternative infeasible.

#### Facts in Support of Finding

Alternative 4 would result in identical potential impacts that are not significant, or can be mitigated to a level of insignificance, identified with construction and operation of the outfall extension and steam stripping system under the proposed project. These impacts include disturbance to coastal dune areas and the ocean bottom for construction of the outfall extension, effects on marine biological resources from relocation of the effluent to a new diffuser location, and increased air emissions from the steam stripping system. The water quality improvements under this alternative would be similar to those under the proposed project, except that the reduction in effluent color would not be as great.

Construction of a secondary treatment system under Alternatives 4 would result in potentially significant impacts that would not occur with the proposed project. Approximately 40 acres of land would be permanently disturbed for construction of secondary treatment ponds. In addition, while this alternative would avoid the air quality impacts associated with the conversion to ACF production, potentially significant increases in nitrogen dioxide, sulfur dioxide, and PM-10 emissions may result from incineration of the sludge generated by secondary treatment. There would also be an increase in the potential carcinogenic risk from emission of chlorinated hydrocarbons during incineration of sludge. This alternative would also result in a potential new source of odors from operation of secondary treatment ponds.

Chlorine dioxide bleaching would reduce the formation and discharge of chlorinated organic compounds, including dioxin, in comparison to existing conditions. However, the formation and discharge of some chlorinated organic compounds would continue under this alternative. In addition, the increased use of chlorine dioxide under this alternative would result in a

CALENDAR PAGE	90
MINUTE PAGE	1245

continued toxic chemical exposure risk.

Alternative 4 would not meet several of the project objectives. Specifically, this alternative would not: (1) eliminate the discharge of dioxin and all other chlorinated organic compounds; (2) reduce effluent color as much at the project; (3) fully protect recreational beneficial uses of the Pacific Ocean adjacent to the Samoa Peninsula; and (4) improve worker and public safety by eliminating the use of all chlorine chemistry in the pulp production process.

Because Alternative 4 generally would result in greater impacts than the project, and would not meet a number of important project objectives, this alternative is rejected as infeasible.

E. Alternative 5: Secondary Treatment, Steam Stripping, Chlorine Dioxide Bleaching; No Outfall Extension

This alternative would not involve the conversion to ACF production or an outfall extension, but would include secondary treatment and chlorine dioxide bleaching, in addition to steam stripping. L-P would construct either an oxygen-activated sludge treatment system, which would involve construction of large microbiological reactor tanks, or aerated treatment ponds, which would require approximately 43 acres of land. In addition, L-P would likely use one or more of its presently inactive power boilers to burn the sludge generated from secondary treatment. The bleaching process would involve the elimination of elemental chlorine and increased use of chlorine dioxide.

Finding

Specific economic, social or other considerations make this alternative infeasible.

Facts in Support of Finding

Alternative 5 would avoid the potential impacts that are not significant, or can be mitigated to a level of insignificance, identified with the construction and operation of the proposed outfall extension. These impacts are related to changes in coastal dune and ocean bottom conditions in the outfall extension construction corridor, disturbance to terrestrial resources, including beach layia populations, from construction of the outfall extension, and effects on marine biological resources from discharge of the effluent at a new diffuser location.

Alternative 5 would result in identical potential impacts that are not significant, or can be mitigated to a level of insignificance, identified with construction and operation of the steam stripping system under the proposed project. These impacts consist of the increased air emissions from the steam

stripping system.

The water quality improvements under this alternative would be similar to those under the proposed project, except that the reduction in effluent color would not be as great.

Construction of a secondary treatment system under Alternatives 5 would result in potentially significant impacts that would not occur with the proposed project. Approximately 40 acres of land would be permanently disturbed for construction of secondary treatment ponds. In addition, while this alternative would avoid the air quality impacts associated with the conversion to ACF production, potentially significant increases in nitrogen dioxide, sulfur dioxide, and PM-10 emissions may result from incineration of the sludge generated by secondary treatment. There would also be an increase in the potential carcinogenic risk from emission of chlorinated hydrocarbons during incineration of sludge. This alternative would also result in a potential new source of odors from operation of secondary treatment ponds.

Chlorine dioxide bleaching would reduce the formation and discharge of chlorinated organic compounds, including dioxin, in comparison to existing conditions. However, the formation and discharge of some chlorinated organic compounds would continue under this alternative. In addition, the increased use of chlorine dioxide under this alternative would result in a continued toxic chemical exposure risk.

Alternative 5 would not meet several of the project objectives. Specifically, this alternative would not: (1) eliminate the discharge of dioxin and all other chlorinated organic compounds; (2) reduce effluent color as much as the project; (3) fully protect recreational beneficial uses of the Pacific Ocean adjacent to the Samoa Peninsula; and (4) improve worker and public safety by eliminating the use of all chlorine chemistry in the pulp production process.

Because Alternative 5 generally would result in greater impacts than the project, and would not meet a number of important project objectives, this alternative is rejected as infeasible.

#### F. Offsite Alternatives

Offsite alternatives would involve the construction of one or more of the three project components at another location.

#### Finding

Specific economic, social or other considerations make potential offsite alternatives infeasible.

#### Facts in Support of Finding

CALENDAR PAGE	92
MINUTE PAGE	1247



The ACF process, the steam stripping system, and the outfall extension each must be integrated into the existing Samoa mill. ACF bleaching involves a substitution of chemicals within an existing pulp production process. The steam stripping system will be incorporated into and treat an existing mill waste stream. The outfall extension must be connected to the existing pipeline. Thus, construction of any of the project components at an alternative location would not be technically feasible. In addition, the outfall extension would not cross a seabed area with unique or highly productive natural resources values that would warrant the selection of a different outfall pipeline route from the present diffuser location to the new diffuser depth. For these reasons, potential offsite alternatives are rejected as infeasible.

CALENDAR PAGE	93
MINUTE PAGE	1248

## 6.0 MITIGATION AND MONITORING PROGRAM

Public Resources Code Section 21081.6, a 1988 amendment to CEQA, requires that Humboldt County "adopt a reporting or monitoring program for the changes to the project which it has adopted or made condition of project approval in order to mitigate or avoid significant effects on the environment." Section 21081.6 also states that "the reporting or monitoring program shall be designed to ensure compliance during project implementation."

The Mitigation Monitoring and Reporting Program for the L-P Pollution Prevention Project is provided in Table 6-1. The objectives and requirements of each mitigation measure identified in Chapter 4.0 are summarized in Table 6-1. Additional information listed for each mitigation measure includes: 1) the responsible party for ensuring that each measure is implemented; 2) how implementation will be verified; and 3) when the mitigation measure would be implemented.

Table 6-1

**Mitigation Program  
Mitigation, Mitigation Monitoring, and Reporting Program for  
the L-P Pollution Prevention Project**

Resource	Measure No.	Summary of Mitigation Measure	Method of Verification	Monitoring Schedule	Responsible Party
Earth	1	Foundation and Structural Design Plan	Plan review and field inspection by Humboldt County Planning and Building Department.	Preconstruction	Humboldt County Planning and Building Department, L-P Building and Inspection Division

**Objectives:** The construction of new buildings and tank placement must conform to foundation and structural design requirements, which would reduce risk of structural damage from seismic and wind shear hazards.

**Requirements:**

- Areas where new structures would be located should be graded and cleared of unsuitable materials and vegetation. Backfilling and fill placement would conform to appropriate building codes.
- Slab-on-grade floors, footings, foundations, and tanks would be designed and constructed to conform with appropriate building, seismic, and wind shear codes.

6-2

MINUTE PAGE	CALENDAR PAGE
	95
	1250

Table 6-1 (Continued)

Resource	Measure No.	Summary of Mitigation Measure	Method of Verification	Monitoring Schedule	Responsible Party
Earth, Terrestrial Resources	2	Dune Stabilization and Revegetation Plan (see Appendix C). Monitoring reports detailing the results of field reviews by a qualified consultant to verify compliance with the approved "Dune Stabilization and Revegetation Plan" shall be prepared. The reports should be submitted following each inspection to appropriate agencies for review and approval including the Humboldt County Planning and Building and the Department of Fish and Game.	Field Inspection	Pre- and post-construction	Humboldt County Planning and Building Department, L-P, and contractors in concert with Calif. Dept. of Fish and Game
	2	<u>Objectives:</u> Minimize impacts of outfall pipeline construction on soil and vegetation by: 1) short-term erosion control during construction; 2) post-construction stabilization of the construction area so as to minimize sand erosion; 3) establishment of vegetation to approximate the types and values of communities removed during construction; and 4) planting of beach layia (federal and state protected) in appropriate habitat to maintain the populations within the construction corridor.			

6-3

MINUTE PAGE	CALENDAR PAGE
	96
	1251

Table 6-1 (Continued)

Resource	Measure No.	Summary of Mitigation Measure	Method of Verification	Monitoring Schedule	Responsible Party
Earth, Terrestrial Resources		<p><u>Requirements (by component):</u></p> <ul style="list-style-type: none"> <li>• Conduct a preconstruction survey in June 1993 to determine if any other rare plant populations are present in the construction corridor.</li> <li>• Flag the location of beach layla populations to minimize the potential disturbance from construction activities.</li> <li>• Remove plant species, such as salt rush, that would be utilized in the final revegetation phase and maintain until winter planting.</li> <li>• Collect native seed from species to be used for revegetation.</li> </ul>			
	2	<ul style="list-style-type: none"> <li>• Mechanically remove beachgrass, lupine, and associated species and stockpile prior to disposal.</li> <li>• After vegetation removal, grade the corridor and stockpile sand on southerly side for erosion control.</li> <li>• Remove driftwood and stockpile for later use.</li> <li>• Water the stockpile area as needed for erosion control.</li> </ul>			

6-4

CALENDAR PAGE 97  
MINUTE PAGE 1252

Table 6-1 (Continued)

Resource	Measure No.	Summary of Mitigation Measure	Method of Verification	Monitoring Schedule	Responsible Party
Earth, Terrestrial Resources	2	<u>Grading and Substrate Placement:</u>			
		<ul style="list-style-type: none"> <li>• Grade construction area to pre-existing contours.</li> <li>• Reincorporate all stockpiled substrate into the graded area.</li> </ul>			
		<u>Mechanical Stabilization:</u>			
		<u>Revegetation:</u>			
		<ul style="list-style-type: none"> <li>• Revegetate the area to approximate the type and quality of habitat disturbed during construction. Native species would be emphasized in the revegetation effort. The types of habitat to be replaced include dune mat and hollow/bramble. Beachgrass would be planted in dune areas where erosion control is needed.</li> </ul>			
		<u>Establishment of Beach Livia Populations:</u>			
		<ul style="list-style-type: none"> <li>• Collect seeds from plants to be disturbed.</li> <li>• Raise plants in a greenhouse for replanting.</li> <li>• Sow seeds in marked plots in dune mat habitat.</li> </ul>			

6-5

CALENDAR PAGE 98  
 MINUTE PAGE 1253

Table 6-1 (Continued)

Resource	Measure No.	Summary of Mitigation Measure	Method of Verification	Monitoring Schedule	Responsible Party
Marine Biology, System Safety and Reliability	3	Anchor Mitigation Plan (see Appendix A)	Visual field inspection during construction by State Lands Commission	Inspection during pipeline outfall extension construction	L-P Project Superintendent, International Diving Services' Project Manager
		<p><u>Objective:</u> Deploy and retrieve anchors without dragging them on the seafloor.</p> <p><u>Requirements:</u></p> <ul style="list-style-type: none"> <li>• Set anchors in precise, predetermined locations.</li> <li>• Set anchors on position with an anchor handling boat, which would eliminate risk of dragging anchor over the seafloor.</li> <li>• Pull each anchor into position with the anchor handling boat one at a time.</li> <li>• Close supervision by boat captain or project superintendent concerning release of the anchor wire and operation of winches as the anchors are placed into position.</li> <li>• Close coordination between the two vessels during running and repositioning the anchors.</li> </ul>			

6-6

MINUTE PAGE  
CALENDAR PAGE 99  
1254

Table 6-1 (Continued)

Resource	Measure No.	Summary of Mitigation Measure	Method of Verification	Monitoring Schedule	Responsible Party
Marine Biology, Terrestrial Biology, System Safety and Reliability	4	Spill Contingency Plan (see Appendix B)	Plan approval by State Lands Commission; verification of equipment and training requirements by State Lands Commission ✓	Implement plan prior to construction; monitor construction activities and report any oil spills.	State Lands Commission, L-P Project Superintendent, International Diving Services' Project Manager ✓
	4	<p><u>Objective:</u> Reduce risks of potential oil spill impacts by implementing a specific set of response procedures for onshore and offshore spill scenarios.</p> <p><u>Requirements:</u></p> <ul style="list-style-type: none"> <li>• Plan would describe the equipment available to respond to a spill.</li> <li>• Plan would describe the procedures needed to contain a spill. ✓</li> <li>• Plan would contain notification requirements for a spill, including immediate contacts with State Lands Commission and the Office of Emergency Services. ✓</li> <li>• Workboat operator would have the following equipment onboard - 400 feet of sorbant boom, packs of sorbant boom, and a skiff with outboard motor.</li> <li>• Plan would require that workers be trained to respond to spills.</li> </ul>			

6-7

KINOSH PAGE  
 CALENDAR PAGE 100  
 1255



Table 6-1 (Continued)

Resource	Measure No.	Summary of Mitigation Measure	Method of Verification	Monitoring Schedule	Responsible Party
System Safety and Reliability	5	<p><b>Critical Operations and Contingency Plan</b></p> <p><b>Objective:</b> To define additional precautionary measures for protection of personnel and the ocean environment when adverse weather and sea conditions occur that might compromise safety of the work force, hinder cleanup operations, or render the deployment of spill containment and recovery equipment unsafe, ineffective, or impossible.</p> <p><b>Requirements:</b></p> <ul style="list-style-type: none"> <li>• Definition of operations that could pose a safety hazard to project personnel, or have a potential for polluting the water in any way through an accidental oil spill, or loss of materials of materials overboard.</li> <li>• Define the critical operating conditions for the equipment in use, including the potential for dragging anchors in rough seas.</li> <li>• Identification of the person responsible for plan implementation.</li> </ul>	State Lands Commission review plan for feasibility ✓	Plan to be provided prior to construction; plan in force during construction period.	<p>Plan preparation, implementation: L-P, L-P construction contractor.</p> <p>Review and enforcement: State Lands Commission ✓</p>

6-8

MINUTE PAGE  
CALENDAR PAGE  
1256  
101

Table 6-1 (Continued)

Resource	Measure No.	Summary of Mitigation Measure	Method of Verification	Monitoring Schedule	Responsible Party
Marine Biology, System Safety and Reliability	6	Offshore and Onshore Construction Monitor	Field Inspection	Construction, and post-construction clean-up	State Lands Commission

**Objective:** Insure conformance to project plans, specifications, structural codes, and accepted industry practices, and for safe execution and mitigation of environmental damage in the beach and offshore areas.

**Requirements:**

- Construction monitor to be present during primary construction periods.
- Monitor provides periodic reports on construction progress and compliance with specifications.

6-9

CALENDAR PAGE 102  
MINUTE PAGE 1257

Table 6-1 (Continued)

Resource	Measure No.	Summary of Mitigation Measure	Method of Verification	Monitoring Schedule	Responsible Party
System Safety and Reliability	7	<p>Outfall Pipeline Post-construction Survey ✓</p> <p><u>Objective:</u> Verify precise pipeline and diffuser location, physical condition in place, burial depth, and to examine for any needed underwater clean up or mitigation of environmental damage caused by construction activities. ✓</p> <p><u>Requirements:</u></p> <ul style="list-style-type: none"> <li>Underwater video survey of installed pipeline; location survey using standard legal survey methods. ✓</li> </ul>	Videotapes, survey reports. ✓	Upon completion of pipeline and diffuser installation	<p>Survey performance: L-P, L-P contractor. ✓</p> <p>Survey review: State Lands Commission.</p>
System Safety and Reliability	8	<p>Annual offshore pipeline inspections ✓</p> <p><u>Objective:</u> To verify pipeline integrity and satisfactory operation of the effluent diffusers. ✓</p> <p><u>Requirements:</u></p> <ul style="list-style-type: none"> <li>Diver surveys, video surveys.</li> </ul>	Field inspection	Annually after the first year the modified outfall is in operation	<p>Inspection: L-P, L-P contractor. ✓</p> <p>Review: State Lands Commission, Regional Water Quality Control Board</p>

6-10

MINUTE PAGE 1258  
 CALENDAR PAGE 103

Table 6-1 (Continued)

Resource	Measure No.	Summary of Mitigation Measure	Method of Verification	Monitoring Schedule	Responsible Party
Marine Biology	9	<p>Outfall construction activities would avoid intensive commercial crab fishing in December and January.</p> <p><u>Objective:</u> Eliminate potential effects of construction on commercial crab fishing.</p> <p><u>Requirements:</u> Allow no construction activities in offshore area during December and January.</p>	Humboldt County and California Department of Fish and Game to verify construction schedule	L-P to inform Humboldt County Planning and Building Department and County Department of Fish and Game	Humboldt County Planning and Building Department with advice from County Department of Fish and Game, L-P Project Superintendent
6-11 Transportation	10	<p>Submit a Construction and Repair Plan for New Navy Base Road.</p> <p><u>Objective:</u> Repair New Navy Base Road to preconstruction conditions.</p> <p><u>Requirements:</u></p> <ul style="list-style-type: none"> <li>Road must be restored to original condition in terms of subsurface and surface characteristics.</li> </ul>	Field inspection by Humboldt County Department of Public Works	Inspection during construction and after road is repaired	Humboldt County Department of Planning and Building

CALENDAR PAGE 104  
MINUTE PAGE 1259

Table 6-1 (Continued)

Resource	Measure No.	Summary of Mitigation Measure	Method of Verification	Monitoring Schedule	Responsible Party
Cultural Resources	11	If significant cultural resources are discovered during construction, activities would be halted until an evaluation by a qualified archaeologist is completed.	Periodic inspections by L-P and contractor	Inspection prior to construction; monitoring would be required during construction.	Humboldt County Planning and Building Department, State Historic Preservation Office, L-P, and contractor, and Humboldt County Planning.
	11	<p><u>Objective:</u> Eliminate potential impacts on important prehistoric and historic cultural resources.</p> <p><u>Requirements:</u></p> <ul style="list-style-type: none"> <li>• Monitor surface disturbance during onshore and offshore construction activities.</li> <li>• If an important site is encountered, a qualified archaeologist would evaluate the site by a test excavation. A site-specific plan would be developed for review and approval by Humboldt County Planning and Building Department.</li> <li>• If an important site cannot be avoided, the site would be documented salvaged following a comprehensive excavation and analysis plan for review and approval by Humboldt County Planning and Building Department.</li> </ul>			

6-12

MINUTE PAGE	1260
CALENDAR PAGE	105

EXHIBIT "F"

RESOLUTION NO. 13-93

RESOLUTION OF PLANNING COMMISSION OF THE COUNTY OF HUMBOLDT  
CERTIFYING THE FINAL ENVIRONMENTAL IMPACT REPORT  
FOR THE  
LOUISIANA-PACIFIC CORPORATION POLLUTION PREVENTION PROJECT

On May 27, 1993, the Planning Commission of the County of Humboldt considered the matter referenced above and resolved as follows:

WHEREAS, Louisiana-Pacific Corporation (L-P) has submitted permit applications to the Humboldt County Department of Planning and Building Inspection for three independent projects, collectively known as the L-P Pollution Prevention Project, proposed at its Samoa Pulp Mill to: (1) extend the existing ocean outfall line to a deeper discharge depth; (2) install chemical storage tanks necessary for process modifications to allow the elimination of chlorine-based pulp bleaching and the production of absolutely-chlorine free (ACF) pulp; and (3) install a steam stripping system for the foul condensate waste stream; and

WHEREAS, the Humboldt County Planning Agency (County) is the Lead Agency for the L-P Pollution Prevention Project under the California Environmental Quality Act (CEQA) (Public Resources Code §§ 21000-21177); and

WHEREAS, the County distributed a Notice of Preparation of an Environmental Impact Report (EIR) on August 28, 1992, to the State Clearinghouse, Responsible Agencies, and other interested parties; and

WHEREAS, the County held a Public Scoping Session in Eureka on September 15, 1992, to receive comments from the public and agencies on the scope and content of the EIR; and

WHEREAS, the Draft EIR was completed on February 26, 1993, and circulated for review and comment to various federal, state, and local agencies, and other interested parties in accordance with CEQA; and

WHEREAS, the County held a public workshop on the Draft EIR in Eureka on March 10, 1993; and

WHEREAS, written responses to comments submitted on the Draft EIR have been prepared and incorporated into the proposed Final EIR; and

WHEREAS, the Final EIR for the L-P Pollution Prevention Project has been prepared in compliance with the CEQA and the State Guidelines for Implementation of CEQA (CEQA Guidelines) (Title 14 of the California Code of Regulations (C.C.R.) §§15000-15387); and

CALENDAR PAGE	106
MINUTE PAGE	1261

WHEREAS, the Final EIR for the L-P Pollution Prevention Project has been presented to this Planning Commission of Humboldt County; and

WHEREAS, this Commission conducted a public hearing to receive testimony with respect to the Final EIR on May 27, 1993, and has reviewed and considered the information contained in the Final EIR prior to making its decision on the L-P Pollution Prevention Project; and

WHEREAS, CEQA (Public Resources Code § 21081) and the CEQA Guidelines (14 C.C.R. § 15091) require that the Planning Commission make one or more of the following findings prior to approval of a proposed project for which an EIR has been completed identifying one or more significant effects of the project, accompanied by a brief statement of facts supporting each finding:

- (1) Changes or alterations have been required in, or incorporated into, the project which mitigate or avoid the significant environmental effects thereof as identified in the EIR.
- (2) Such changes or alterations are within the responsibility and jurisdiction of another public agency and such changes have been adopted by such other agency, or can and should be adopted by such other agency.
- (3) Specific economic, social, or other considerations make infeasible the mitigation measures or project alternatives identified in the EIR; and

WHEREAS, the CEQA Guidelines (14 C.C.R. § 15093(a)) require the Planning Commission to balance the benefits of a proposed project against the unavoidable environmental risks in determining whether to approve the project, and provide that the unavoidable adverse environmental effects may be considered "acceptable" if such adverse effects are outweighed by the benefits of the project; and

WHEREAS, this Commission adopts the Statement of Findings and Facts included as Attachment A to this Resolution as required by CEQA (Public Resources Code § 21081) and the CEQA Guidelines (14 C.C.R. § 15091).

NOW, THEREFORE, BE IT RESOLVED:

1. That the Planning Commission does hereby certify the Final EIR for the L-P Pollution Prevention Project as complete and adequate in that it addresses all potential environmental effects of the proposed project in compliance with the requirements of CEQA and the CEQA Guidelines.

CALENDAR PAGE	107
MINUTE PAGE	1262

2. That although the Final EIR identifies certain potentially significant environmental effects that could result if the L-P Pollution Prevention Project is approved, all potentially significant effects have been eliminated or substantially reduced to a level of insignificance by virtue of project design considerations, imposition of mitigation measures on the project and conditions of approval. The project would not result in any unavoidable significant adverse environmental effects.

3. That all mitigation measures identified in the Final EIR have been incorporated into the project or imposed as conditions of approval.

4. That the Final EIR identifies all reasonable alternatives to the proposed project that could feasibly attain the basic objectives of the project.

5. That the facts set forth in Attachment A and incorporated herein are true and are supported by substantial evidence in the record, including the Final EIR for the L-P Pollution Prevention Project.

AYES: Bish, Brown, Eitzen, Feeney, Kirby

NOES: NONE

ABSTAIN: NONE

ABSENT: Sorensen

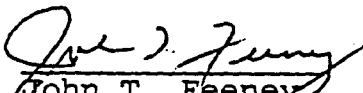
  
John T. Feeney  
Chair

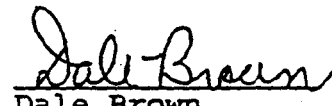
  
Dale Brown  
Vice-Chair

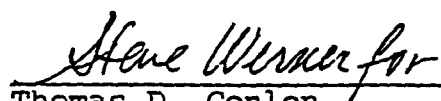
  
Thomas D. Conlon  
Director of Planning

CALENDAR PAGE	108
MINUTE PAGE	1263



NOTICE OF DETERMINATION

EXHIBIT "G"

To: [X] Office of Planning and Research  
1400 Tenth Street, Room 121  
Sacramento, CA 95814

From: Planning Division of the  
Humboldt County Planning  
and Building Department  
3015 H Street  
Eureka, CA 95501

[X] County Clerk, County of Humboldt

Subject: Filing of Notice of Determination in compliance with Section 21108 or 21152 of the Public Resources Code.

Project Title: LOUISIANA-PACIFIC CORPORATION POLLUTION PREVENTION PROJECT  
Conditional Use Permit, Coastal Development Permit and Special Permit, Case Nos  
CUP-08-92, CDP-20-92, SP-69-92  
Assessor Parcel Number: APN 401-111-06, 401-111-07, and 401-112-07

State Clearinghouse Number: 92093011  
Lead Agency Contact Person: Robert London, Planner II  
Area Code/Telephone/Extension: (707) 445-7541

Project Location: The L-P Samoa Mill and project site is located on the North Spit of the Samoa Peninsula, which lies between the Pacific Ocean on the west and Humboldt Bay to the east in Humboldt County, California.

Project Description: Conditional Use Permit , Coastal Development Permit Application for three independent projects, collectively known as the Louisiana-Pacific Corporation Pollution Prevention Project. The component projects and objectives are: 1) seam stripping of foul condensates to reduce effluent toxicity and odor, and to comply with BOD and pH limitations; 2) installation of tankage and other process modifications to allow for substitution of other bleaching compounds for chlorine in the bleaching process to produce absolutely chlorine-free (ACF) pulp, to reduce effluent color and chronic toxicity, and to improve worker safety by eliminating hazardous chlorine storage and use; and 3) extension of the existing wastewater discharge outfall to a greater depth and greater distance offshore to provide more effective mixing, and much less frequent discoloration of the ocean surface.

This is to advise that the Humboldt County Planning Commission has approved the above described project on May 27, 1993 and has made the following determinations regarding the above described project:

1. The project will not have a significant effect on the environment.
2. An Environmental Impact Report was prepared for this project pursuant to the provisions of CEQA.
3. Mitigation measures were made a condition of the approval of the project.
4. A statement of Overriding Considerations was not adopted for this project.
5. Findings were made pursuant to the provisions of CEQA.

This is to certify that the Final EIR with comments and responses and record of project approval is available to the General Public at: Humboldt County Planning Division, 3015 H Street, Eureka, California 95501

R. London June 29, 1993 Planner II  
Signature (Public Agency) Date Title

Date received for filing at OPR  
(Conv 205\sub1\pnod.doc,word)6/29/93

Revised October 1989

CALENDAR PAGE	109
MINUTE PAGE	1264

copy to Marc ZEPPEFELU

NO TEXT ON THIS PAGE

CALENDAR PAGE _____	1265
MINUTE PAGE _____	