

MINUTE ITEM
This Calendar Item No. C07
was approved as Minute Item
No. 07 by the State Lands
Commission by a vote of 2
to 0 at its 6-21-93
meeting.

CALENDAR ITEM

C07

A 4
S 1

06/21/93
PRC 5858
J. Ludlow

APPROVE AMENDMENT NO. 2 TO GENERAL LEASE -
COMMERCIAL USE

LESSEE:

Tahoe Sunnyside, a California limited partnership
21 Blackberry Court
Lafayette, California 94549

AREA, TYPE LAND AND LOCATION:

A 0.241-acre parcel of submerged land located in Lake Tahoe
at Sunnyside, Placer County

LAND USE:

Proposed reconstruction of an existing rock crib pier.

EXISTING LEASE TERMS:

Lease period:
Forty (40) years beginning July 1, 1980.

CONSIDERATION:

Minimum annual rental of \$750 against five percent (5%) of
annual gross income derived from the rental of boat slips,
pier, and moorings; one cent per gallon of gas sold annually
to a maximum of 100,000 gallons and one-and-one-half cents
per gallon thereafter; five year rent review.

AMENDED LEASE TERMS:

Lease period:
Forty (40) years beginning July 1, 1980

Public liability insurance:

Combined single limit coverage of not less than
\$500,000 per occurrence for bodily injury and property
damage.

Special:

This amendment authorizes the reconstruction of the
rock crib pier located at the lakeward southern and
eastern boundaries of the marina.

CALENDAR PAGE	78
MINUTE PAGE	1074

CALENDAR ITEM NO. C07 (CONT'D)

BASIS FOR CONSIDERATION:

Pursuant to 2 Cal. Code Regs. 2003

APPLICANT STATUS:

Applicant is owner of the upland.

PREREQUISITE CONDITIONS, FEES AND EXPENSES:

Filing fee, processing fee, environmental fees and Fish and Game fee have been received.

STATUTORY AND OTHER REFERENCES:

A. P.R.C.: Div. 6, Parts 1 and 2; Div. 13.

B. Cal. Code Regs.: Title 3, Div. 3; Title 14, Div. 6.

AB 884:

10/16/93

OTHER PERTINENT INFORMATION:

1. Pursuant to the Commission's delegation of authority and the State CEQA Guidelines (14 Cal. Code Regs. 15025), the staff has prepared a Proposed Negative Declaration identified as EIR ND 620, State Clearinghouse No. 93052056. Such Proposed Negative Declaration was prepared and circulated for public review pursuant to the provisions of CEQA.

Based upon the Initial Study, the Proposed Negative Declaration, and the comments received in response thereto, there is no substantial evidence that the project will have a significant effect on the environment. (14 Cal. Code Regs. 15074(b)).

2. This activity involves lands identified as possessing significant environmental values pursuant to P.R.C. 6370, et seq. Based upon the staff's consultation with the persons nominating such lands and through the CEQA process, it is the staff's opinion that the project, as proposed, is consistent with its use classification.

A Mitigation Monitoring Plan has been prepared in conformance with the CEQA (Section 21081.6, P.R.C.)

CALENDAR PAGE	79
MINUTE PAGE	1075

CALENDAR ITEM NO. C07 (CONT'D)

3. The State's lessee proposes to reconstruct an existing "L" shaped rock crib pier in two phases. The first phase (approximately 12 weeks) will consist of reconstructing the first 115 feet of pier from the shore lakeward. The second phase (approximately 12-16 weeks) will consist of reconstructing the second 175 feet of pier.
4. The rock crib reconstruction will be accomplished by removing the rock from the most lakeward crib and placed onto a barge. It will then be stored on a paved parking lot outside of the backshore. One crib will be reconstructed at a time by placing rock from the crib to be reconstructed into the crib with new wood rounds and, finally, using rock placed on the paved parking area for the most landward crib. Reconstructing the pier in a "leap frog" method will cause the least disturbance to the lakebed.
5. A fuel pump and two hose reels located on the pier will be drained and temporarily removed during phase one of the reconstruction. The pumps are fed by a pipe leading from underground storage tanks which are located on that portion of the marina area not affected by the reconstruction project.
6. No materials will be stored or placed, nor will any activity associated with the construction or maintenance of the project, be conducted above the low water line (elevation 6223 feet, Lake Tahoe Datum) of the subject property. This procedure will prevent any disturbance to the habitat of *Rorippa subumbellata*, commonly called the Tahoe Yellow Cress, a State-listed endangered plant species.
7. Commission staff will monitor the pier reconstruction project in accordance with the Monitoring Program included within the Proposed Negative Declaration.
8. The subject property was physically inspected by staff for purposes of evaluating the impact of the proposed activity on the public trust.
9. This permit is conditioned on Permittee's conformance with the Tahoe Regional Planning Agency's Shorezone Ordinance. If any structure authorized by the Permit

CALENDAR PAGE	80
MINUTE PAGE	1076

CALENDAR ITEM NO. C07 (CONT'D)

is found to be in nonconformance with the Tahoe Regional Planning Agency's Shorezone ordinance, and if any alterations, repairs, or removal required pursuant to said ordinance are not accomplished within the designated time period, then this permit is automatically terminated, effective upon notice by the State, and the site shall be cleared pursuant to the terms thereof.

If the location, size, or number of any structure hereby authorized is to be altered, pursuant to order of the Tahoe Regional Planning Agency, Permittee shall request the consent of the State to make such alteration.

10. The property was physically inspected by staff for purposes of evaluating the impact of the proposed activity on the Public Trust.
11. All other terms and conditions of the lease remain in full force and effect.

APPROVALS OBTAINED:

Tahoe Regional Planning Agency, Placer County

FURTHER APPROVALS REQUIRED:

United States Army Corps of Engineers, State Lands Commission

EXHIBITS:

- A: Land Description
- B: Negative Declaration and Monitoring Program

IT IS RECOMMENDED THAT THE COMMISSION:

1. CERTIFY THAT A NEGATIVE DECLARATION, EIR ND 620 STATE CLEARING HOUSE NO. 93052056, WAS PREPARED FOR THIS PROJECT PURSUANT TO THE PROVISIONS OF THE CEQA AND THAT THE COMMISSION HAS REVIEWED AND CONSIDERED THE INFORMATION CONTAINED THEREIN.
2. ADOPT THE PROPOSED NEGATIVE DECLARATION AND DETERMINE THAT THE PROJECT, AS APPROVED, WILL NOT HAVE A SIGNIFICANT EFFECT ON THE ENVIRONMENT.

CALENDAR PAGE	81
MINUTE PAGE	1077

CALENDAR ITEM NO. C07 (CONT'D)

3. ADOPT THE MITIGATION MONITORING PLAN, AS CONTAINED IN EXHIBIT "B" ATTACHED HERETO.
4. FIND THAT THIS ACTIVITY IS CONSISTENT WITH THE USE CLASSIFICATION DESIGNATED FOR THE LAND PURSUANT TO P.R.C. 6370, ET SEQ.
5. AUTHORIZE THE AMENDMENT OF LEASE PRC 5858 ISSUED TO TAHOE SUNNYSIDE, A CALIFORNIA LIMITED PARTNERSHIP, EFFECTIVE JULY 1, 1993, FOR THE RECONSTRUCTION, USE AND MAINTENANCE OF AN EXISTING ROCK CRIB PIER LOCATED ON THE LAND DESCRIBED ON EXHIBIT "A" ATTACHED, AND BY REFERENCE MADE A PART HEREOF.
6. FIND THAT ALL OTHER TERMS AND CONDITIONS OF THE LEASE REMAIN IN FULL FORCE AND EFFECT.

CALENDAR PAGE	82
MINUTE PAGE	1078

NOTE:

THE MARINA PIER WILL BE RECONSTRUCTED TO THE EXISTING DIMENSIONS ONLY. THE ROCK CRIBS WILL BE REPLACED BETWEEN THE MEAN LOW WATER MARK, EL. 6223.0, AND DECK ELEVATION, EL. 6232.0, LAKE TAHOE DATUM. NO INCREASE IN SIZE OR CHANGE IN LOCATION WILL OCCUR.

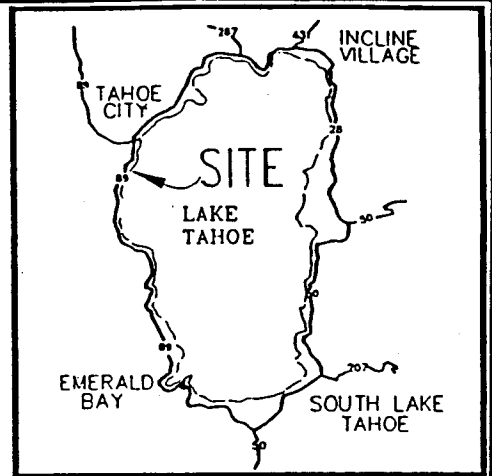

LOCATION MAP

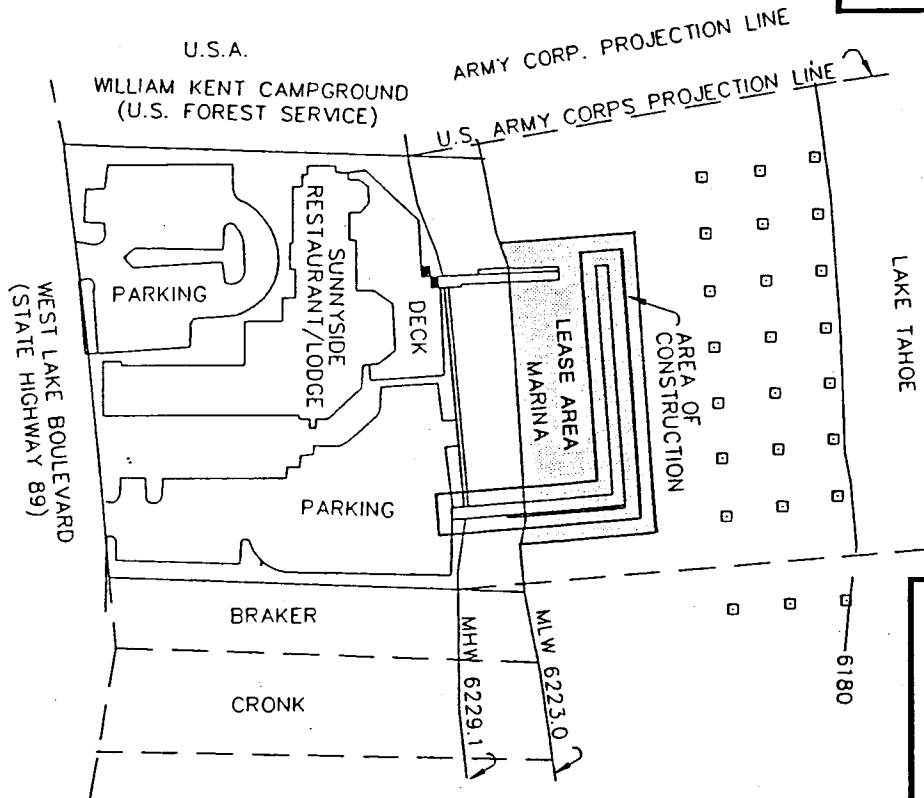

LEGEND
GROIN □

EXHIBIT "A"
PRC 5858
Sunnyside Marina
APN 84- 140 - 28
LAKE TAHOE
PLACER COUNTY
 Sheet 1 of 2 Sheets



This Exhibit is solely for purposes of generally defining the lease premises, and is not intended to be, nor shall it be construed as, a waiver or limitation of any State interest in the subject or any other property.

CALENDAR PAGE	83
MINUTE PAGE	1079

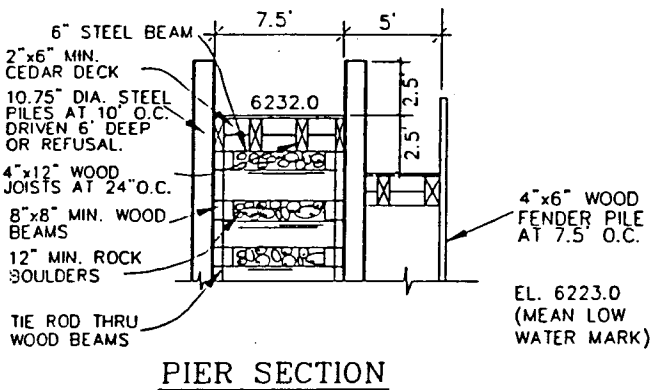
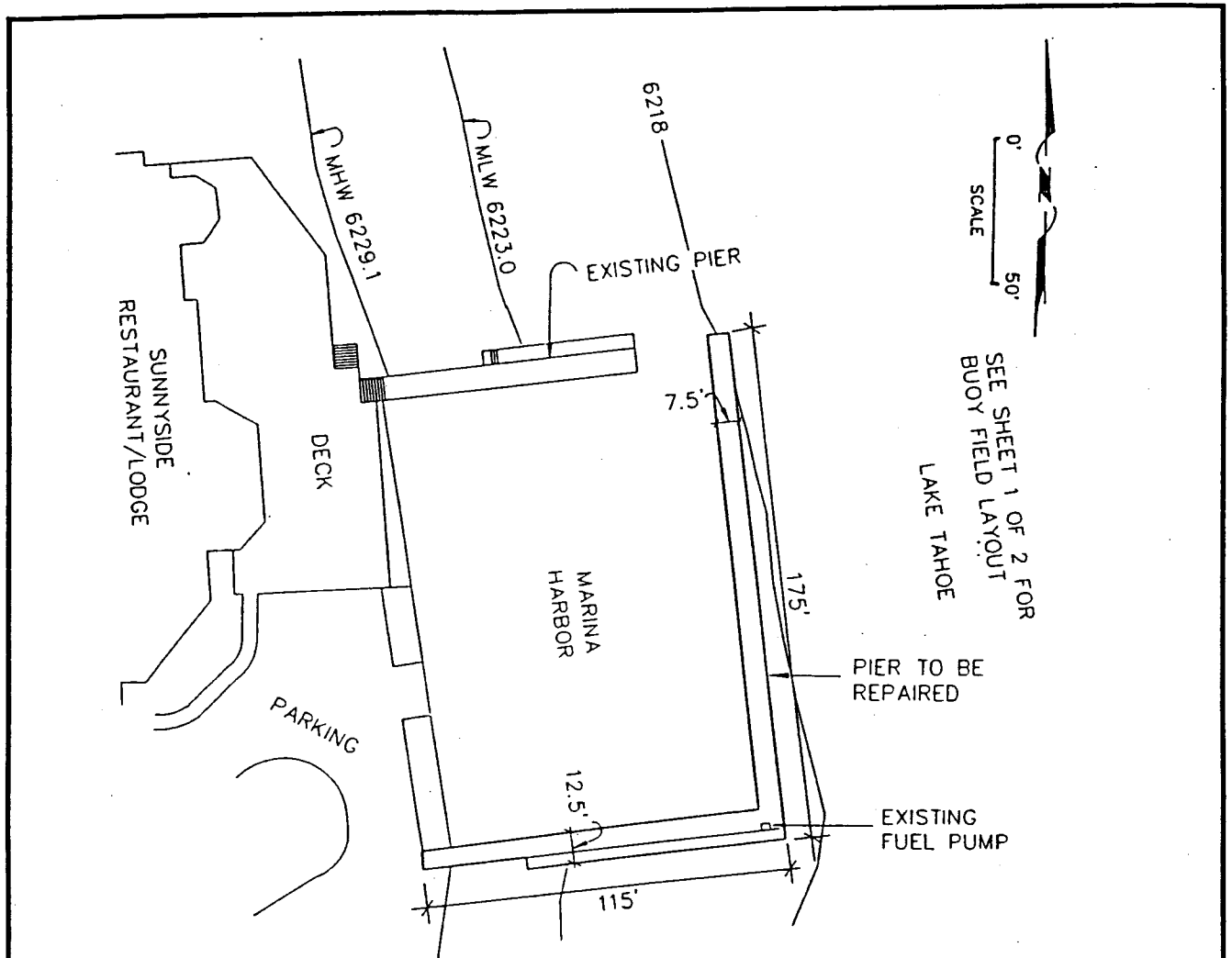
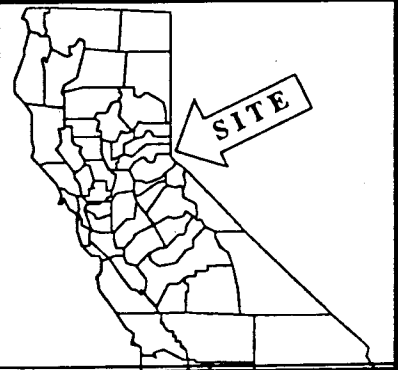

EXHIBIT "A"
 PRC 5858
 Sunnyside Marina
 APN 84- 140 - 28
 LAKE TAHOE
 PLACER COUNTY
 Sheet 2 of 2 Sheets



This Exhibit is solely for purposes of generally defining the lease premises, and is not intended to be, nor shall it be construed as, a waiver or limitation of any State interest in the subject or any other property.

CALENDAR PAGE	84
MINUTE PAGE	1080

STATE LANDS COMMISSION

LEO T. McCARTHY, Lieutenant Governor
GRAY DAVIS, Controller
THOMAS W. HAYES, Director of Finance

EXECUTIVE OFFICE
1807 - 13th Street
Sacramento, CA 95814
CHARLES WARREN
Executive Officer

May 20, 1993
File: WP 5858
ND 620

NOTICE OF PUBLIC REVIEW OF A PROPOSED NEGATIVE DECLARATION
(SECTION 15073 CCR)

A Negative Declaration has been prepared pursuant to the requirements of the California Environmental Quality Act (Section 21000 et seq., Public Resources Code), the State CEQA guidelines (Section 15000 et seq., Title 14, California Code Regulations), and the State Lands Commission Regulations (Section 2901 et seq., Title 2, California Code Regulations) for a project currently being processed by the staff of the State Lands Commission.

The document is attached for your review. Comments should be addressed to the State Lands Commission office shown above with attention to the undersigned. All comments must be received by June 19, 1993.

Should you have any questions or need additional information, please call the undersigned at (916) 322-7826.

Doug Miller

DOUG MILLER
Division of Environmental
Planning and Management

(LL)

Attachment

CALENDAR PAGE	85
MINUTE PAGE	1081

STATE LANDS COMMISSION

LEO T. McCARTHY, *Lieutenant Governor*
GRAY DAVIS, *Controller*
THOMAS W. HAYES, *Director of Finance*

EXECUTIVE OFFICE
1807 - 13th Street
Sacramento, CA 95814

CHARLES WARREN
Executive Officer

PROPOSED NEGATIVE DECLARATION

File: WP 5858
ND 620
SCH No. 93052056

Project Title: Sunnyside Partial Pier Reconstruction

Project Proponent: Sunnyside Marina Inc.

Project Location: 1850 West Lake Blvd., Sunnyside area, APN 84-040-20, Lake Tahoe, Placer County.

Project Description: Proposed authorization to repair/reconstruct an "L" shaped rock crib pier in two phases. Includes replacing cribbing, pilings and decking.

Contact Person: Doug Miller Telephone: (916) 322-7826

This document is prepared pursuant to the requirements of the California Environmental Quality Act (Section 21000 et seq., Public Resources Code), the State CEQA Guidelines (Section 15000 et seq., Title 14, California Code Regulations), and the State Lands Commission regulations (Section 2901 et seq., Title 2, California Code Regulations).

Based upon the attached Initial Study, it has been found that:

this project will not have a significant effect on the environment.

mitigation measures included in the project will avoid potentially significant effects.

CALENDAR PAGE	86
MINUTE PAGE	1082

I. BACKGROUND INFORMATION

- A. Applicant: Sunnyside Marina, Inc.
Attn: John Sears
21 Blackberry Court
Lafayette, CA 94549
- B. Checklist Date: 5 / 19 / 93
- C. Contact Person: Doug Miller
 Telephone: (916) 322-7826
- D. Purpose: Partial pier reconstruction at Sunnyside Marina.
- E. Location: 1850 West Lake Blvd., Sunnyside Area, Lake Tahoe, Placer County, APN 84-140-20.
- F. Description: Proposed authorization to repair/reconstruct "L" shaped rock crib pier in two phases. Includes replacing cribbing, piling and decking.
- G. Persons Contacted: _____
Kevin Agan, Vail Engineering

II. ENVIRONMENTAL IMPACTS. (Explain all "yes" and "maybe" answers)

A. Earth. Will the proposal result in:	Yes	Maybe	No
1. Unstable earth conditions or changes in geologic substructures?	—	—	<u>X</u>
2. Disruptions, displacements, compaction, or overcovering of the soil?	—	—	<u>X</u>
3. Change in topography or ground surface relief features?	—	—	<u>X</u>
4. The destruction, covering, or modification of any unique geologic or physical features?	—	—	<u>X</u>
5. Any increase in wind or water erosion of soils, either on or off the site?	—	—	<u>X</u>
6. Changes in deposition or erosion of beach sands, or changes in siltation, deposition of erosion which may modify the channel of a river or stream or the bed of the ocean or any bay, inlet or lake?	—	—	<u>X</u>
7. Exposure of all people or property to geologic hazards such as earthquakes, landslides, mudslides, ground failure, or similar hazards?	—	—	<u>X</u>

CALENDAR PAGE	<u>87</u>	<u>X</u>
MINUTE PAGE	<u>1083</u>	<u>X</u>

B. Air. Will the proposal result in:

- 1. Substantial air emissions or deterioration of ambient air quality?
- 2. The creation of objectional odors?
- 3. Alteration of air movement, moisture or temperature, or any change in climate, either locally or regionally?.....

C. Water. Will the proposal result in:

- 1. Changes in the currents, or the course or direction of water movements, in either marine or fresh waters?
- 2. Changes in absorption rates, drainage patterns, or the rate and amount of surface water runoff?
- 3. Alterations to the course or flow of flood waters?
- 4. Change in the amount of surface water in any water body?
- 5. Discharge into surface waters, or in any alteration of surface water quality, including but not limited to temperature, dissolved oxygen or turbidity?
- 6. Alteration of the direct on or rate of flow of ground waters?
- 7. Change in the quantity of ground waters, either through direct additions or withdrawals, or through interception of an aquifer by cuts or excavations?
- 8. Substantial reduction in the amount of water otherwise available for public water supplies?
- 9. Exposure of people or property to water-related hazards such as flooding or tidal waves?
- 10. Significant changes in the temperature, flow or chemical content of surface thermal springs?

D. Plant Life. Will the proposal result in:

- 1. Change in the diversity of species, or number of any species of plants (including trees, shrubs, grass, crops, and aquatic plants)?
- 2. Reduction of the numbers of any unique, rare or endangered species of plants?
- 3. Introduction of new species of plants into an area, or in a barrier to the normal replenishment of existing species?.....
- 4. Reduction in acreage of any agricultural crop?

E. Animal Life. Will the proposal result in:

- 1. Change in the diversity of species, or numbers of any species of animals (birds, land animals including reptiles, fish and shellfish, benthic organisms, or insects)?
- 2. Reduction of the numbers of any unique, rare or endangered species of animals?
- 3. Introduction of new species of animals into an area, or result in a barrier to the migration or movement of animals?
- 4. Deterioration to existing fish or wildlife habitat?

F. Noise. Will the proposal result in:

- 1. Increase in existing noise levels?
- 2. Exposure of people to severe noise levels?

G. Light and Glare. Will the proposal result in:

- 1. The production of new light or glare?

H. Land Use. Will the proposal result in:

- 1. A substantial alteration of the present or planned land use of an area?

I. Natural Resources. Will the proposal result in:

- 1. Increase in the rate of use of any natural resources?
- 2. Substantial depletion of any nonrenewable resources?

CALENDAR PAGE	88
MINUTE PAGE	1084

J. Risk of Upset. Does the proposal result in:		
1. A risk of an explosion or the release of hazardous substances (including, but not limited to, oil, pesticides, chemicals, or radiation) in the event of an accident or upset conditions?	—	<u>X</u>
2. Possible interference with emergency response plan or an emergency evacuation plan?	—	<u>X</u>
K. Population. Will the proposal result in:		
1. The alteration, distribution, density, or growth rate of the human population of the area?	—	<u>X</u>
L. Housing. Will the proposal result in:		
1. Affecting existing housing, or create a demand for additional housing?	—	<u>X</u>
M. Transportation/Circulation. Will the proposal result in:		
1. Generation of substantial additional vehicular movement?	—	<u>X</u>
2. Affecting existing parking facilities, or create a demand for new parking?	—	<u>X</u>
3. Substantial impact upon existing transportation systems?	—	<u>X</u>
4. Alterations to present patterns of circulation or movement of people and/or goods?	—	<u>X</u>
5. Alterations to waterborne, rail, or air traffic?	—	<u>X</u>
6. Increase in traffic hazards to motor vehicles, bicyclists, or pedestrians?	—	<u>X</u>
N. Public Services. Will the proposal have an effect upon, or result in a need for new or altered governmental services in any of the following areas:		
1. Fire protection?	—	<u>X</u>
2. Police protection?	—	<u>X</u>
3. Schools?	—	<u>X</u>
4. Parks and other recreational facilities?	—	<u>X</u>
5. Maintenance of public facilities, including roads?	—	<u>X</u>
6. Other governmental services?	—	<u>X</u>
O. Energy. Will the proposal result in:		
1. Use of substantial amounts of fuel or energy?	—	<u>X</u>
2. Substantial increase in demand upon existing sources of energy, or require the development of new sources?	—	<u>X</u>
P. Utilities. Will the proposal result in a need for new systems, or substantial alterations to the following utilities:		
1. Power or natural gas?	—	<u>X</u>
2. Communication systems?	—	<u>X</u>
3. Water?	—	<u>X</u>
4. Sewer or septic tanks?	—	<u>X</u>
5. Storm water drainage?	—	<u>X</u>
6. Solid waste and disposal?	—	<u>X</u>
Q. Human Health. Will the proposal result in:		
1. Creation of any health hazard or potential health hazard (excluding mental health)?	—	
2. Exposure of people to potential health hazards?	—	
R. Aesthetics. Will the proposal result in:		
1. The obstruction of any scenic vista or view open to the public, or will the proposal result in the creation of an aesthetically offensive site open to public view?	—	

CALENDAR PAGE	89
MINUTE PAGE	1085

S. Recreation. Will the proposal result in:	Yes	Maybe	No
1. An impact upon the quality or quantity of existing recreational opportunities?	—	—	<u>X</u>
T. Cultural Resources			
1. Will the proposal result in the alteration of or the destruction of a prehistoric or historic archeological site? ...	—	—	<u>X</u>
2. Will the proposal result in adverse physical or aesthetic effects to a prehistoric or historic building, structure, or object?	—	—	<u>X</u>
3. Does the proposal have the potential to cause a physical change which would affect unique ethnic cultural values?	—	—	<u>X</u>
4. Will the proposal restrict existing religious or sacred uses within the potential impact area?	—	—	<u>X</u>
U. Mandatory Findings of Significance.			
1. Does the project have the potential to degrade the quality of the environment, reduce the habitat of a fish or wildlife species, cause a fish or wildlife population to drop below self-sustaining levels, threaten to eliminate a plant or animal community, reduce the number or restrict the range of a rare or endangered plant or animal or eliminate important examples of the major periods of California history or prehistory?	—	—	<u>X</u>
2. Does the project have the potential to achieve short-term, to the disadvantage of long-term, environmental goals?	—	—	<u>X</u>
3. Does the project have impacts which are individually limited, but cumulatively considerable?	—	—	<u>X</u>
4. Does the project have environmental effects which will cause substantial adverse effects on human beings, either directly or indirectly?	—	—	<u>X</u>

III. DISCUSSION OF ENVIRONMENTAL EVALUATION (See Comments Attached)

IV. PRELIMINARY DETERMINATION

On the basis of this initial evaluation:

I find the proposed project **COULD NOT** have a significant effect on the environment, and a **NEGATIVE DECLARATION** will be prepared.

I find that although the proposed project could have a significant effect on the environment, there will not be a significant effect in this case because the mitigation measures described on an attached sheet have been added to the project. A **NEGATIVE DECLARATION** will be prepared.

I find the proposed project **MAY** have a significant effect on the environment, and an **ENVIRONMENTAL IMPACT REPORT** is required.

Date: 5 / 3 / 93

Doug Miller

For the State Lands	CALENDAR PAGE	90
MINUTE PAGE		1086

PROJECT DESCRIPTION

PROJECT NARRATIVE

This project proposes the repair of the existing outer "L" shaped rock crib pier which is an integral part of the existing marina facility. The marina is generally comprised of two rock crib piers. Another rock crib, which makes up the marina's northern boundary, was reconstructed with Commission authorization in the spring of 1992. The proposed "L" shaped rock crib pier to be repaired makes up the southern and eastern (lakeward) boundaries of the marina. Repair of the pier is proposed to be phased over 2 to 3 years or within the terms of the permit. The first phase (approximately 12 weeks) will consist of reconstructing the first 115 feet of pier from the shore lakeward, which comprises the southern boundary of this marina beginning at the landward terminus. The second phase (approximately 12 - 16 weeks) of work will be the second 175 feet of pier which comprises the eastern (lakeward) boundary of the marina which runs parallel to the shoreline, beginning at the phase one construction and ending at the marina's lake entrance. Repair and replacement of the existing rock cribbing will utilize wood members and existing rock crib boulders. The repair of the rock cribbing will occur between mean low water (EL. 6223.0) and the pier deck. The scope of work includes replacing existing wood pilings with 10.75" dia. steel piles, 6" steel "H" beams, 2" x 6" min. cedar deck with one catwalk located on the southern extent of the "L" shaped rock crib pier. (see Exhibit "A"-1).

The existing (15 plus years) public fuel facility (fuel pump and two hose reels) on the pier will be drained and temporarily removed during the phase one portion of reconstruction. The underground storage tanks for the pumps are located about 50 yards to the west on the upland property and the pump is fed by a pipe. The tanks are located on that portion of marina area not affected by the reconstruction project. Permits will be obtained from Placer County pertaining to the fuel facility. (See Exhibit "A"-2).

CONSTRUCTION METHOD

ROCK CRIB RECONSTRUCTION: Remove rock from most lakeward crib and place onto barge and store material on paved parking lot or other acceptable area as designated by TRPA and SLC personel outside of the backshore with appropriate erosion control measures. Remove rock from most landward crib and place onto barge and store material. Replace existing wood piles by pile driving steel piles over existing wood piles driven 6' deep or refusal. Starting at the shore and working lakeward, the contractor will reconstruct one crib at a time with 10"-12" diameter min. wood rounds; install vertical tie rod assemblies at each corner of rock cribs; reconstruct one crib at a time by placing rock

from the crib to be
CALENDAR PAGE

91

MINUTE PAGE

1087

reconstructed into the crib with new wood rounds; thus, reconstructing the rock crib pier in a "leap frog" manner in order to minimize disturbance. A turbidity screen surrounding the project shall be used at the TRPA compliance inspector's option if resuspension of earthen materials occurs before or during construction of this project.

PIER RECONSTRUCTION: Repair of existing rock crib pier is to be by barge with pile driver. Caissons or sleeve will be used when sediment is resuspended while driving piles. Anchorage of barge will be to existing structure and/or anchors required for adequate stabilization. All construction wastes will be collected onto barge and disposed at the nearest dumpster/sanitary landfill site. During reconstruction the rock from the cribs will be placed on the barge and stored there until the cribs are repaired; then, the rock will be replaced into the cribs. Small boats and tarps will be under the construction areas to provide collection of construction debris; thus, preventing any discharge of wastes to the lake. If disturbed lakebottom sediments are found due to the construction activity associated with the installation of this project, the affected areas will be hand rolled and/or rock cobble will be hand picked to reconsolidate the lakebottom sediments. There will be no storage of materials above the low water line of the subject property. This will prevent disturbance of what may be considered Tahoe Yellow Cress Habitat.

DESCRIPTION OF ENVIRONMENTAL SETTING

The proposed site lies within the Ward Creek drainage area and is approximately 0.7 miles north of the inflow of Ward Creek to Lake Tahoe. Ward Creek is a major influent stream to Lake Tahoe (the third largest) and is nearly always perennial even during years of low amounts of precipitation to the Tahoe Basin. An ephemeral stream is present approximately 50 feet north of the property line adjacent to which the pier repair project is being proposed. This stream carries water flow from a channel which traverses William Kent Campground and also storm/snow melt water running off the road (State Route 89 and roads draining to that road).

The shoreline (6222.7 to 6229.1 feet elevation) of Lake Tahoe at the site is entirely composed of cobbles except in the center 200 foot section of the property where the marina is situated. There are no areas of sand on the shoreline adjacent to the property where the pier project is proposed. Near and landward of the 6,229.1 foot elevation contour there are some gravels and soils present. Cobbles generally range in size from 0.5 to 2.0 inches in diameter with a few larger cobbles (6 to 12 inches) scattered on shore. The shoreline slope is fairly gradual (4%) between the 6,222 and 6,224 foot elevation contours then increases landward to the 6,229 foot elevation contour (17%).

CALENDAR PAGE	92
MINUTE PAGE	1088

The backshore area at the proposed project site is almost entirely covered by Sunnyside Resort structure (deck restaurant, hotel, paved parking areas). There is a concrete wall 6,229 foot elevation contour at the landward end of the proposed pier to be repaired. The wall extends approximately 75 feet northward along the 6,229 foot elevation contour to about 15 feet from the property line.

At the end of the concrete wall northward to the property line, the backshore area has some vegetation present on either side of a dirt path that extends from the shoreline westward (landward). The plants include Mariposa Manzanita (Arctostaphylos mariposa), Willow (Salix sp.), Black Cottonwood (Populous trichocarpa), Jeffrey Pine (Pinus jeffreyi), and White Fir (Abies concolor).

At the southern side of the property, 160 to 210 feet south of the proposed pier to be repaired, there is virtually no bank or backshore vegetation. There are two small areas of non-native grass lawn, a few small Jeffrey pines (Pinus jeffreyi), however, the majority of the backshore area is paved over or covered by the Sunnyside Restaurant/Lodge.

No Tahoe Yellow Cress (Rorippa subumbellata Rollins) was found on the proposed property site or on adjacent shoreline/backshore areas within 165 feet north and 300 feet south of the property where the proposed project is located. No specimens of the non-endangered (Rorippa curvisiliqua) were found in the area either.

The shorezone in the area of the proposed project is mapped spawning habitat on the Prime Fish Habitat Maps identified by the Tahoe Regional Planning Agency. There are existing piers located approximately 160 feet from the property line and approximately 500 feet to the north of the property line.

CALENDAR PAGE	93
MINUTE PAGE	1089

DISCUSSION OF ENVIRONMENTAL EVALUATION
SUNNYSIDE MARINA, INC.
EXISTING FUEL PUMP AND RECONSTRUCTION OF A ROCK CRIB PIER

WP 5858

A. Earth

1. No. The rock crib pier repair project is confined to the surface and will not create any unstable conditions or change any geological structure.
2. No. There will be a temporary removal of the rock used in the crib being repaired which will be stored on the barge and in the parking lot or other acceptable area as designated by SLC and TRPA personel. After reconstruction of the crib, the rock will be returned to the crib and the project area will be returned to its former condition. This operation will not overcover or disturb any new areas.
3. No. This project will not create any changes in ground surface relief. The rock cribs are sitting on the cobble surface and there will not be any excavating.
4. No. The geology in the project area consists of glacial and alluvial deposits. The driving of piles will not change any geological or physical features.
5. No. This pier reconstruction project is simply repairing an existing structure and will have no effect on wind or water erosion on or off the site.
6. No. This project is a repair project confined to an existing structure which will not create any channel changes nor erosion of beach sands. The beach is comprised of cobble with no sand present to erode.
7. No. The repair of the existing structure will in no way create any geological hazards.

B. Air

1. No. The reconstructed pier will not affect the air quality; however, there will be a minor amount of diesel fumes created by the barge during the reconstruction period. This would be equivalent to a diesel truck. This increase in minor emissions will last about 12 to 16 weeks during each phase of the normal daily construction hours. The fuel facility will be removed during reconstruction and replaced when the first phase is completed. The existing fuel pump and hose reels, when operated, will add minimal gasoline fumes to the

atmosphere, but these are immediately dispersed by the prevailing winds. The project will not create an increase in the use of the fueling facility.

2. No. The reconstructed pier will not create objectionable odors; however, diesel fumes will be generated during the day by the operation of the barge but will be immediately dissipated by the prevailing winds. The existing fuel facility will be temporarily removed during reconstruction. Prior to removal the fuel system will be drained to minimize spillage and odors. After reconstruction, the gasoline pump and hose reels, when operated, may create some minor temporary fumes and odors in the immediate vicinity of the fueling area before being dispersed by the wind; however, these odors are not considered significant.
3. No. The reconstruction of the pier will not create any major changes in air movements, temperature, climate, nor create any abnormal weather conditions.

C. Water

1. No. The repair of the pier is of a static nature and will not create any changes in water currents or movements. The existing fuel facility is on the pier and will have no effect on water movement.
2. No. The reconstruction of the existing pier will not affect absorption rates, drainage patterns, etc. The area adjacent to the pier is submerged.
3. No. The repairing of the existing pier will not create any new effects upon flood waters.
4. No. This project will not alter the surface water in Lake Tahoe.
5. Maybe. Mitigation measures incorporated into the project description to reduce the construction debris from entering the water include using small boats with tarps beneath the construction area to catch any falling debris from entering Lake Tahoe. Additional measures include the use of caissons or sleeves and turbidity screens to surround the project area when necessary to isolate turbid waters from mixing with undisturbed waters.

The existing fuel facility has not posed a problem; however, the people fueling their boats could inadvertently spill fuel. The hose reels have a long hose attached to them which allows the boat to moor beside the fuel facility to fill its tanks. This type of an operation minimizes spilling because

use all tanks and or	
CALENDAR PAGE	95
MINUTE PAGE	1091

gas cans are filled in the boat by the long hose. Hand pouring of fuel from gas can to fuel tank is eliminated, and the chances of spilling is reduced.

6. No. The geology of the project area is composed of glacial and alluvial deposits. The reconstruction of the existing pier will not create new structures that would alter any ground water flows.
7. No. There will not be any changes to ground water flows caused by the pier reconstruction which is the repair of an existing structure. The existing pump and reels on the pier will have no effect on any ground water flows.
8. No. There will be no reductions to ground water flows from either the pier reconstruction or the existing fuel facility on the marina. The reconstruction project is the repair of an existing pier and will not disturb any aquifers or public water lines.
9. No. The pier reconstruction project and the existing marine fuel facility will not expose people or property to water-related hazards such as tidal waves.
10. No. Neither the pier reconstruction project nor the existing pump and reels on the marina will create any significant changes on water temperature.

D. Plant Life

1. Maybe. There will be a temporary change in aquatic sessile plants for a period of approximately 12 to 16 weeks during each phase of the reconstruction period. This temporary change will only affect the area of the rock crib pier repair. This will not constitute a permanent or significant change. The indigenous aquatic flora will shortly begin recolonizing the affected area after the project has been completed.
2. No. There are no rare or endangered species on the property. In the soils and vegetation report for Tahoe Yellow Cress (Rorippa subumbellata) habitat, the area is described as composed of cobbles to a depth of 4 to 6 inches or more, which is unsuitable for the growth of Tahoe Yellow Cress.
3. No. The pier reconstruction project and the existing fuel facility on the pier will not introduce new species to the area nor exclude existing species from becoming established.
4. No. The reconstruction project and the existing marine fuel facility will not reduce the acreage of agricultural

CALENDAR PAGE	96
MINUTE PAGE	1092

crops in Lake Tahoe.

E. Animal Life

1. No. The reconstruction project involving the rock crib repair will be conducted during the non-spawning season between July 1, and October 1 to minimize the impact on fish spawning habitat. The work is scheduled to be done during the summers of 1993, 1994, and possibly 1995. During each phase of construction, there will be a 12 to 16 week temporary change in aquatic animal life within that specific reconstruction area. Upon completion of each phase of the reconstruction, the indigenous aquatic animals will re-occupy any voids created during the repair operation. The existing fuel facility on the pier will have no effect on aquatic animal life.
2. No. There have not been any rare or endangered aquatic animals reported within the project area.
3. No. The rock crib pier reconstruction project will not introduce any new species to the area nor create a new barrier to aquatic animals.
4. No. The reconstruction project will not reduce the aquatic animal habitat area upon completion.

F. Noise

1. No. The repaired pier will not create additional noise levels; however, there will be a temporary 12 to 16 week period during the reconstruction periods in 1993 and 1994 when noise levels will increase. The noise levels will return to normal after construction has been completed. The Sunnyside Restaurant/Lodge complex will act as a buffer, attenuating noise levels between the construction area and Highway 89 and the general public. The existing fueling facility will not change present or future noise levels. All internal combustion engines will be equipped with mufflers in good repair help attenuate engine noise levels.
2. No. The repaired pier will not expose people to severe noise levels; however, there will be 12-16 week periods in 1993 and 1994 when the noise levels increase during the period of reconstruction. Upon completion of the project, the noise levels will assume normality. The construction personnel will be subjected to severe noise levels, but they wear hearing protective devices. The Sunnyside Restaurant/Lodge is located between the construction area and Highway 89 which will act as a buffer, and the general population will not be exposed to

CALENDAR PAGE

97

MINUTE PAGE

1093

this increased noise level. The existing fuel pump and reels will not affect this type of noise level.

G. Light and Glare

1. No. Neither the pier reconstruction nor the marine fuel facility will result in creating new light or glare.

H. Land Use

1. No. The repair of the existing pier is not enlarging the pier; therefore, it will not alter the present or planned use of the area. The Sunnyside Marina/Lodge is a limited partnership and only its membership have access to its facilities.

I. Natural Resources

1. No. This project is repairing an existing pier which will not have any effect upon the use rate of any natural resource. The Sunnyside Marina is a private recreational marina and this project will not create any changes.
2. No. The Sunnyside Marina/Lodge has a closed membership and the reconstruction of the rock crib pier and the use of the existing fuel pump will not create any changes which could deplete any nonrenewable resource. All facilities are existing; therefore, there is no change in the intensity of use.

J. Risk of Upset

1. Maybe. There is probably some risk of release of hazardous materials during the reconstruction phase, but mitigation measures have been incorporated into the project described in the event that there is an accidental spill during the construction phase. Small boats and/or tarps will be in place beneath the pier during the construction phase to intercept anything that might get dumped or spilled before entering the water. Caissons or sleeves will be available to isolate turbid waters or spills. The fuel for the underground fuel pump can be turned off at either the tanks or the pump. There is an attendant present; however, boaters using the fuel pump are cautious when fueling their recreational boats and are aware of the potential of an explosion. The nozzles on the hoses have shut off valves to keep from overflowing when filling fuel tanks or gas cans. The proposed project will decrease the risk of explosion by removing a navigation hazard when the pier is repaired.

CALENDAR PAGE	98
MINUTE PAGE	1094

2. No. To the contrary, upon completion of the reconstruction of the pier this marina will be a safer harbor and would be an asset to an emergency evacuation plan. The fuel pump could supply emergency fuel when needed.

K. Population

1. No. The Sunnyside Marina/Lodge has a closed membership and the existing pier reconstruction project will not in any way alter the population using the marina facility.

L. Housing

1. No. Neither this reconstruction project nor the existing fuel pump will create a demand for additional housing.

M. Transportation/Circulation

1. No. This is a private marina, and the pier repair is for the benefit of the members of the marina and not the general public. All the marina facilities are for the members, which include the parking lot, restaurant, lodge, marina, fuel pump, etc. are existing. There are no facilities being added to attract more people. The use of these facilities will not be changed by this project nor will there be any substantial increase in vehicle movement created by this project.
2. No. See #1 above.
3. No. See #1 above.
4. No. See #1 above.
5. No. See #1 above.
6. No. See #1 above.

N. Public Services

1. No. This is a private marina and the pier repair and the existing fuel pump will not create any additional use or increase of use by the general public. All the facilities for the members of the marina are existing. Public access to the marine fuel pump is from Lake Tahoe. This use will not change. This project will not create any new demands on government agencies and services such as fire, police protection, parks and recreation, road maintenance, etc.

2. No. See #1 above.
3. No. See #1 above.
4. No. See #1 above.
5. No. See #1 above.
6. No. See #1 above.

O. Energy

1. No. This pier repair project and existing fuel pump will not have any affect on additional energy consumption. There will be no new demands for energy as a result of these activities.
2. No. See #1 above.

P. Utilities

1. No. The reconstruction of the rock crib pier and the existing fuel pump will not create any changes in utilities. This project is for the benefit of the members of the Sunnyside Marina. There will be no additions to the existing facilities nor will there be any new demands created by this project which will affect the current uses of power, communications, water, septic tanks, storm water drainage, or solid waste disposal.
2. No. See #1 above.
3. No. See #1 above.
4. No. See #1 above.
5. No. See #1 above.
6. No. See #1 above.

Q. Human Health

1. No. The repair of the rock crib pier will be eliminating a navigational hazard to boaters using the marina. The existing fuel pump will not create any changes in health hazards.
2. No. The existing fuel pump will not create an increase in the potential hazard existing for an explosion during boat refueling. The only people near the pump are those using the pump to refuel their boat.

attendant managing the use of the fuel pump to assure safety during the fueling operation.

R. Aesthetics

1. No. The Sunnyside Marina is an existing facility. There are no new facilities being added. The project will be completed during the off-tourist season. The repaired pier will actually enhance the view currently being marred by a damaged pier. The existing pump will not create any change in aesthetics.

S. Recreation

1. Yes. The repair of the pier will eliminate a safety hazard making boating safer for the users of the marine facility. This will create a positive change on the quality of recreation by repairing a navigational hazard. The existing pump will not cause any changes in recreation use.

T. Cultural Resources

1. No. This project consists of repairing an existing pier, and maintaining an existing fuel pump. There are no identified cultural, ethnic, religious, or sacred uses pertinent to this project area.
2. No. See No.# 1 above.
3. No. See No.# 1 above.
4. No. See No.# 1 above.

U. Mandatory Findings of Significance

1. No. The pier is only to be repaired. There will be about a 12 week period during reconstruction when the indigenous aquatic biota will be displaced but will recolonize and return to normal after the project is completed. Mitigation measures are incorporated into the project to protect Lake Tahoe during the reconstruction phase of the operation. Additional mitigation measures will protect water quality. The existing pump will not create any new significant effects.
2. No. There will be a short term disruption of the environment in the immediate vicinity of the pier being repaired for four weeks during the pier reconstruction. There will not be any long term significant changes.

3. No. The Sunnyside Marina is an existing private commercial marina facility. The pier repair project does not create impacts which will increase the propensity for cumulative effects.
4. No. To the contrary the pier reconstruction project will remove a navigation hazard which will have a direct positive effect on boaters safety. This project will not create a significant adverse effect on the public. The existing pump will not create any new or significant effects.

CALENDAR PAGE	102
MINUTE PAGE	1098

EXHIBIT "B"
MONITORING PROGRAM
FOR THE SUNNYSIDE MARINA PIER RECONSTRUCTION

1. Impact: The proposed project may cause minimal turbidity to lake waters during the driving of piling into the lake bed, and there is the possibility of an upset or spill of construction materials or debris.

Project Modification:

- a) Use of caissons or vertical cylinders (sleeves) to prevent the release of resuspended sediments during pile placement activities;
- b) Small boats and/or tarps will be placed under the reconstruction area as necessary to collect construction debris; and,
- c) Waste materials will be collected onto a barge or dumpsters for disposal at an approved landfill site.

Monitoring:

Staff of the State Lands Commission, or its designated representative, will periodically monitor the pier reconstruction project during the placement of the pilings.

2. Impact: The proposed project is located in designated fish spawning habitat and could have an impact on the habitat.

Project Modification:

- a) The pier reconstruction project involving disturbance to the lake bed will be conducted during the non-spawning season, July 1 - October 1, to reduce impacts to fish habitat.
- b) Crib rock from the first crib will be stored in the parking lot. The remaining crib rock will be stored on the barge during the "leap frog" construction process. The rock from the first crib will be used to fill the last crib.

Monitoring:

Staff of the State Lands Commission, or its designated representative, will periodically site inspect the pier reconstruction project to ensure the proposed activity will occur within the allowable construction time period.

Rocks to be removed from the first crib will be stored in the parking lot. These rocks will be used to fill the last crib. The other crib rocks will be stored on the barge during the leap frog construction process.

CALENDAR PAGE	104
---------------	-----

MINUTE PAGE	1100-
-------------	-------